

HOW TO CHARGE LEAD ACID BATTERIES

Dependable performance and long service life of your sealed lead acid battery will depend upon correct battery charging. Following incorrect charging procedures or using inadequate charging equipment can result in decreased battery life and/or poor battery performance. The selection of a suitable SLA battery charger and the methods used to charge it is just as important as choosing the right battery for the application.

Power Sonic recommends you select a charger designed for the chemistry of your battery. This means we recommend using a sealed lead acid battery charger, like the the A-C series of SLA chargers from Power Sonic, when charging a sealed lead acid battery.

BATTERY CHARGING TECHNIQUES

Sealed lead acid batteries may be charged by using any of the following charging techniques:

Constant Voltage

Constant Current

Taper Current

Two Step Constant Voltage

To obtain maximum battery service life and capacity, along with acceptable recharge time and economy, constant voltage-current limited charging is best.

To charge a sealed lead acid battery, a DC voltage between 2.30 volts per cell (float) and 2.45 volts per cell (fast) is applied to the terminals of the battery. Depending on the state of charge (SoC), the cell may temporarily be lower after discharge than the applied voltage. After some time, however, it should level off.

During charge, the lead sulfate of the positive plate becomes lead dioxide. As the battery reaches full charge, the positive plate begins generating dioxide causing a sudden rise in voltage due to decreasing internal resistance. A constant voltage charge, therefore, allows detection of this voltage increase and thus control of the current charge amount.

BATTERY CHARGING CHARACTERISTICS

During constant voltage or taper charging, the battery's current acceptance decreases as voltage and state of charge increase. The battery is fully charged once the current stabilizes at a low level for a few hours. There are two criteria for determining when a battery is fully charged: (1) the final current level and (2) the peak charging voltage while this current

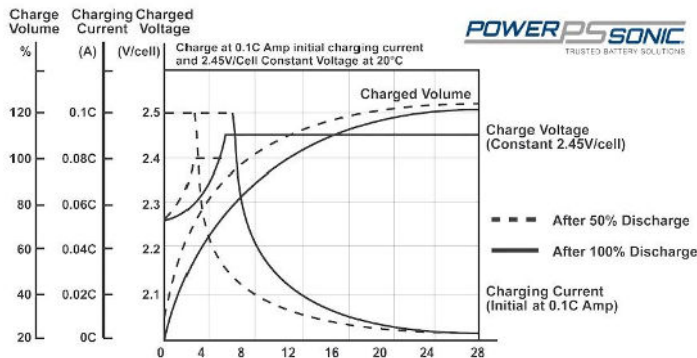

Typical sealed lead acid battery charge characteristics for cycle service where charging is non-continuous and peak voltage can be higher.

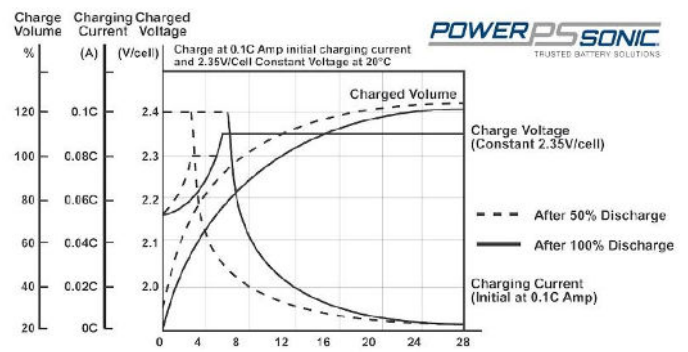

Typical characteristics for standby service type battery charge. Here, charging is continuous and the peak charge voltage must be lower.

HOW TO CHARGE LEAD ACID BATTERIES

BATTERY CHARGING METHODS

Selecting the appropriate charging method for your sealed lead acid battery depends on the intended use (cyclic or float service), economic considerations, recharge time, anticipated frequency and depth of discharge (DoD), and expected service life. The goal of any charging method is to control the charge current at the end of the charge.

CONSTANT VOLTAGE CHARGING

Constant voltage charging is the best method to charge sealed lead acid batteries. Depending on the application, batteries may be charged either on a continuous or non-continuous basis. In applications where standby power is required to operate, for example a security system or uninterruptible power supply (UPS), when the AC power has been interrupted, continuous float charging is recommended. Non-continuous cyclic charging is used primarily with portable equipment where charging on an intermittent basis is appropriate, such as electric wheelchairs and mobile medical carts.

The constant voltage charge method applies a constant voltage to the battery and limits the initial charge current. It is necessary to set the charge voltage according to specified charge and temperature characteristics. Inaccurate voltage settings can cause either over-charge or under-charge. This charging method can be used for both cyclic and standby applications.

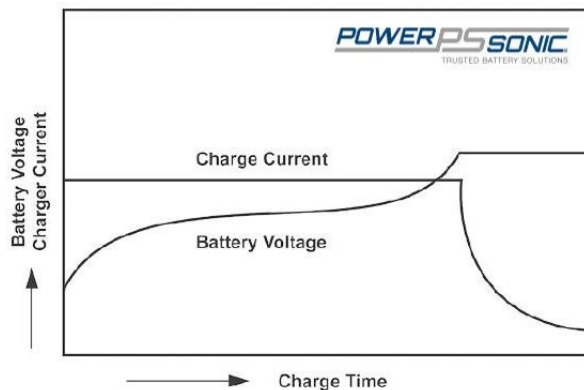
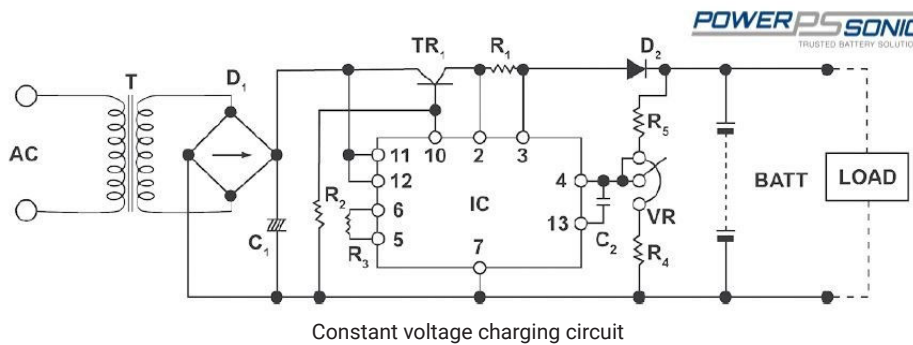

HOW TO CHARGE LEAD ACID BATTERIES

CONSTANT CURRENT CHARGING

Constant current charging is suited for applications where discharged ampere-hours of the preceding discharge cycle are known. Charge time and charge quantity can easily be calculated, however an expensive circuit is necessary to obtain a highly accurate constant current. Monitoring of charge voltage or limiting of charge time is necessary to avoid excessive overcharge of the battery.

While this charging method is very effective for recovering the capacity of a SLA battery that has been stored for an extended period of time, or for occasional overcharging to equalize cell capacities, it lacks specific properties required in today's electronic environment.

TAPER CURRENT CHARGING

The taper current charging method is not recommended as it is somewhat abusive of sealed lead acid batteries and can shorten service life. However, because of the simplicity of the circuit and low cost, taper current charging is extensively used to charge multiple numbers and/or for cyclic charging.

When using a taper current battery charger the charger time should be limited or a charging cut-off circuit needs to be incorporated to prevent over-charge.

In a taper current charging circuit, the current decreases in proportion to the voltage rise. When designing a taper charger always consider power voltage fluctuations. In this event the internal resistance drop will convert to heat. Heat generated by the circuit should be measured and if required a heat sink should be incorporated in the design.

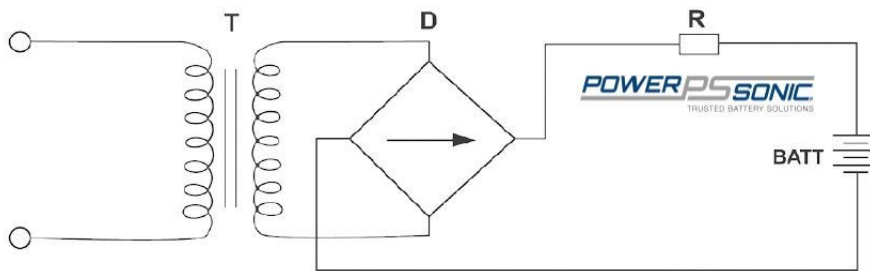

Taper current charging circuit

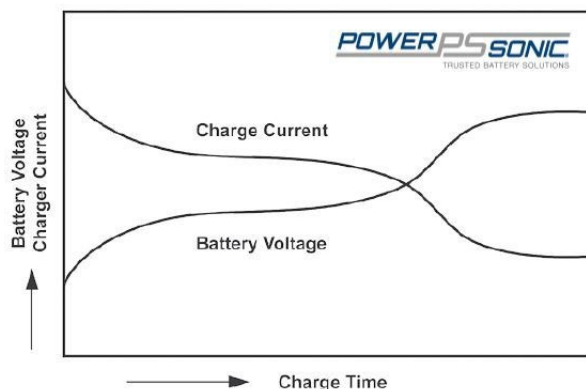

Taper current charging characteristics for this type of basically unregulated charger

HOW TO CHARGE LEAD ACID BATTERIES

OVERCHARGING A LEAD ACID BATTERY

As a result of too high a charge voltage excessive current will flow into the battery, after reaching full charge, causing decomposition of water in the electrolyte and premature aging.

At high rates of overcharge a battery will progressively heat up. As it gets hotter, it will accept more current, heating up even further. This is called thermal runaway and it can destroy a battery in as little as a few hours.

UNDERCHARGING A LEAD ACID BATTERY

If too low a charge voltage is applied, the current flow will essentially stop before the battery is fully charged. This allows some of the lead sulfate to remain on the electrodes, which will eventually reduce battery capacity.

Batteries which are stored in a discharged state, or left on the shelf for too long, may initially appear to be "open circuited" or will accept far less current than normal. This is caused by a phenomenon called "sulfation". When this occurs, leave the charger connected to the battery. Usually, the battery will start to accept increasing amounts of current until a normal current level is reached. If there is no response, even to charge voltages above recommended levels, the battery may have been in a discharged state for too long to recover, and in which case a replacement SLA battery will be needed.

BATTERY CYCLE CHARGING

Cyclic (or cycling) applications generally require recharging be done in a relatively short time. The initial charge current, however, must not exceed $0.30 \times C$ amps. Just as battery voltage drops during discharge, it slowly rises during charge. Full charge is determined by voltage and inflowing current. When, at a charge voltage of 2.45 ± 0.05 volts/cell, the current accepted by the battery drops to less than $0.01 \times C$ amps (1% of rated capacity), the battery is fully charged and the charger should be disconnected or switched to a float voltage of 2.25 to 2.30 volts/cell. The voltage should not be allowed to rise above 2.45 ± 0.05 volts/cell.

BATTERY STANDBY CHARGING

Standby applications generally do not require that the battery be charged as fast or as frequently as in cycle operation. However, the battery must be kept constantly charged to replace the energy that is expended due to internal loss and deterioration of the battery itself. Although these losses are very low in Power Sonic lead acid batteries, they must be replaced at the rate the battery self discharges; at the same time the battery must not be given more than these losses or it will be overcharged. To accomplish this, a constant voltage method of charging called standby or float charging is used.

The recommended constant float voltage is 2.25 - 2.30 volts per cell. Maintaining this float voltage will allow the battery to define its own current level and remain fully charged without having to disconnect the charger from the battery. The trickle current for a fully charged battery floating at the recommended charge voltage will typically hover around the 0.001C rate (7mA for a 7AH battery, for example.)

The float charger is basically a constant voltage power supply. As with cycle chargers, care must be taken not to exceed the initial charge current of $0.30 \times C$ amperes.

HOW TO CHARGE LEAD ACID BATTERIES

TWO STEP CONSTANT VOLTAGE CHARGING

This method uses two constant voltage devices. In the initial charge phase the high voltage setting is used. When charging is nearly complete and the charge voltage has risen to a specified value (with the charge current decreased), the charger switches the voltage to the lower setting. This method allows rapid charging in cycle or float service without the possibility of overcharging, even after extended charging periods.

Temperature compensated

Select R_s to give correct float voltage at desired min. current: $0.6/R_3 = I_{max}$.

Select R_{isw} to turn on Q2 at desired current $I_{sw} = R_{isw}/0.6$

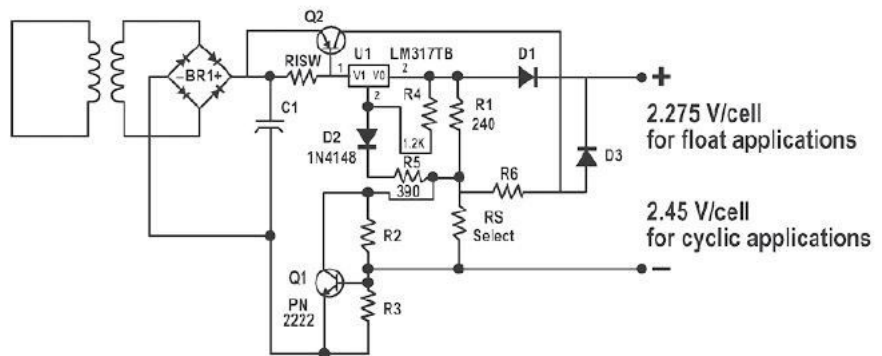

Dual stage current limited SLA battery charger

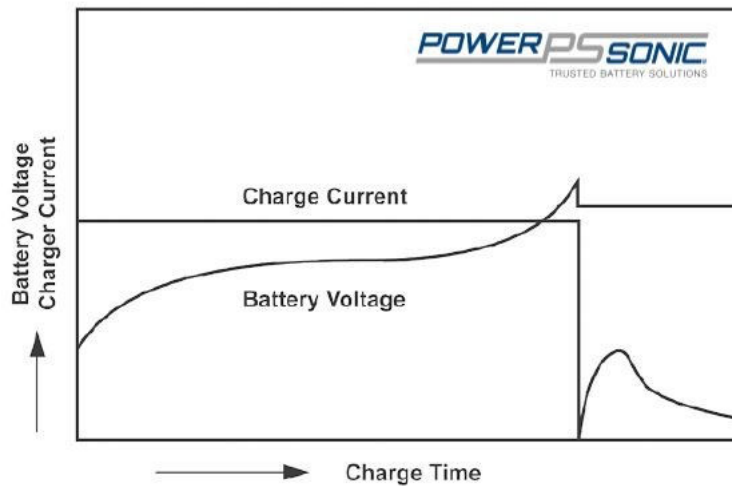

Two-step constant voltage charging characteristics

GLOBAL HEADQUARTERS
(USA AND INTERNATIONAL EXCLUDING EMEA)

Power-Sonic Corporation
365 Cabela Dr Suite 300,
Reno, Nevada 89523
USA
T: +1 619 661 2020
E: customer-service@power-sonic.com

POWER-SONIC EMEA
(EMEA – EUROPE, MIDDLE EAST AND AFRICA)

Smitspol 4, 3861 RS Nijkerk,
The Netherlands
T NL: + 31 33 7410 700
T UK: + 44 1268 560 686
T FR: + 33 344 32 18 17
E: salesEMEA@power-sonic.com

HOW TO CHARGE LEAD ACID BATTERIES

CHARGING BATTERIES IN SERIES

Lead acid batteries are strings of 2 volt cells connected in series, commonly 2, 3, 4 or 6 cells per battery. Strings of lead acid batteries, up to 48 volts and higher, may be charged in series safely and efficiently. However, as the number of batteries in series increases, so does the possibility of slight differences in capacity. These differences can result from age, storage history, temperature variations or abuse.

Fully charged batteries should never be mixed with discharged batteries when charging batteries in series. The discharged batteries should be charged before connection.

When a single constant voltage charger is connected across an entire high voltage string, the same current flows through all cells in the string. Depending on the characteristics of the individual batteries, some may overcharge while others remain in a slightly undercharged condition.

To minimize the effects of individual battery differences, use batteries of the same age, manufacturer, amp hour, and history and, if possible, charge in strings of no greater than 24 or 48 volts.

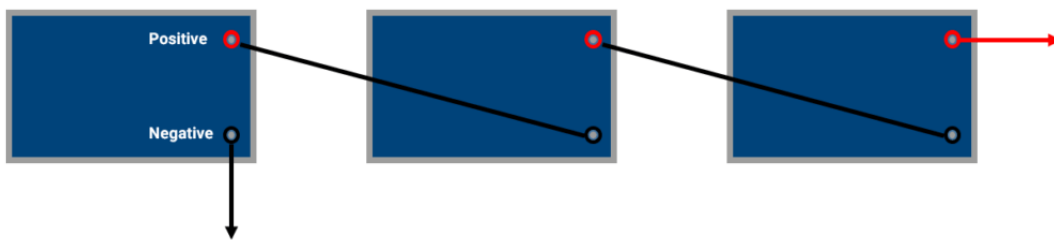

CHARGING BATTERIES IN PARALLEL

Lead acid batteries may be used in parallel with one or more batteries of equal voltage. When connecting batteries in parallel, the current from a charger will tend to divide almost equally between the batteries. No special matching of batteries is required. If the batteries of unequal capacity are connected in parallel, the current will tend to divide between the batteries in the ratio of capacities (actually, internal resistances).

When charging batteries in parallel, where different ratios of charge are to be expected, it is best to make provisions to assure that the currents will not vary too much between batteries.

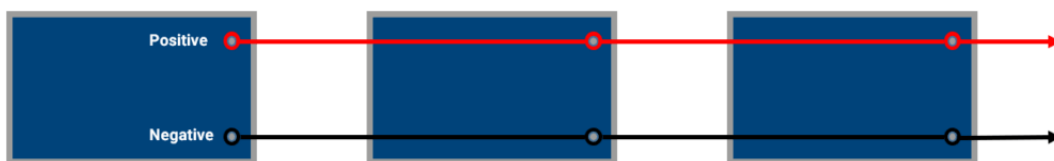

HOW TO CHARGE LEAD ACID BATTERIES

BATTERY TEMPERATURE COMPENSATION

Power Sonic sealed lead acid batteries perform well both at low and high temperatures. At low temperatures, however, charge efficiency is reduced; at temperatures above 45°C (113°F), charge efficiency increases so rapidly that there is a danger of thermal runaway if temperature compensation is not precise.

The effect of temperature on charge voltage is less critical in float applications than in cyclic use, where relatively high charge currents are applied for the purpose of short recharge times.

Temperature effects should definitely be considered when designing or selecting a charging system. Temperature compensation is desirable in the charging circuit, especially when operating outside the range of 5°C to 35°C

(41°F to 95°F). The temperature coefficient is -2mV/cell/°C below 20°C (68°F) in float use and -6mV/cell/ °C below 20°C in cyclic use. For higher temperatures the charge voltage should be correspondingly decreased.

The battery temperature compensation chart below shows the recommended charge voltages for different temperatures based on ambient charge voltage per cell.

Temperature	Cyclic Use (V)	Float Use (V)
-40°C (-40°F)	2.85 – 2.95	2.38 – 2.43
-20°C (-4°F)	2.67 – 2.77	2.34 – 2.39
-10°C (14°F)	2.61 – 2.71	2.32 – 2.37
0°C (32°F)	2.55 – 2.65	2.30 – 2.35
10°C (50°F)	2.49 – 2.59	2.28 – 2.33
20°C (68°F)	2.43 – 2.53	2.26 – 2.31
25°C (77°F)	2.40 – 2.50	2.25 – 2.30
30°C (86°F)	2.37 – 2.47	2.24 – 2.29
40°C (104°F)	2.31 – 2.41	2.22 – 2.27
50°C (122°F)	2.25 – 2.35	2.20 – 2.25

TOP UP CHARGING LEAD ACID BATTERIES

All batteries lose capacity through self-discharge, it is recommended that a “top up charge” be applied to any battery that has been stored for a long period of time, prior to putting the battery into service.

To successfully top up charge a battery stored for more than 12 months, the open circuit voltage must be higher than 2.0 volts per cell, in this case, always confirm open circuit voltage prior to attempting top up charging.

GLOBAL HEADQUARTERS (USA AND INTERNATIONAL EXCLUDING EMEA)

Power-Sonic Corporation
365 Cabela Dr Suite 300,
Reno, Nevada 89523
USA
T: +1 619 661 2020
E: customer-service@power-sonic.com

POWER-SONIC EMEA (EMEA – EUROPE, MIDDLE EAST AND AFRICA)

Smitropol 4, 3861 RS Nijkerk,
The Netherlands
T NL: + 31 33 7410 700
T UK: + 44 1268 560 686
T FR: + 33 344 32 18 17
E: salesEMEA@power-sonic.com

HOW TO CHARGE LEAD ACID BATTERIES

BATTERY CHARGING EFFICIENCY

The charging efficiency (η) of a battery is expressed by the following formula:

$$\eta = \frac{\text{AH Discharged After Fully Charged}}{\text{AH Delivered to Battery During Charge}}$$

The charging efficiency varies depending upon the state of charge of the battery, temperatures, and charging rates. The left graph illustrates the concept of the state of charge and charging efficiency. The right graph shows Power Sonic sealed lead acid batteries exhibit very high charging efficiency, even when charged at low charging rates

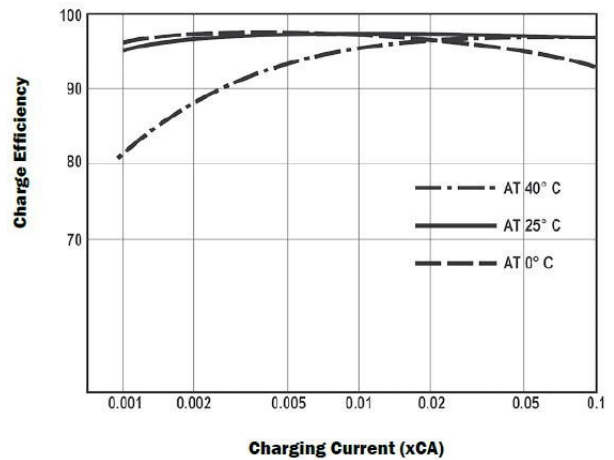
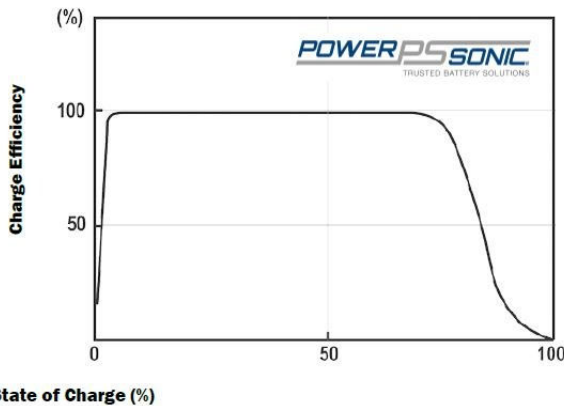

It is always important to match your charger to deliver the correct current and voltage for the battery you are charging. For example, you wouldn't use a 24V charger to charge a 12V battery.

If you have any questions about an existing charger's capability with one of our products, please give us a call or send us an email. We would be happy to assist you with your charging needs.

GLOBAL HEADQUARTERS (USA AND INTERNATIONAL EXCLUDING EMEA)

Power-Sonic Corporation
365 Cabela Dr Suite 300,
Reno, Nevada 89523
USA
T: +1 619 661 2020
E: customer-service@power-sonic.com

POWER-SONIC EMEA (EMEA – EUROPE, MIDDLE EAST AND AFRICA)

Smitspol 4, 3861 RS Nijkerk,
The Netherlands
T NL: + 31 33 7410 700
T UK: + 44 1268 560 686
T FR: + 33 344 32 18 17
E: salesEMEA@power-sonic.com