

SECTION A-A

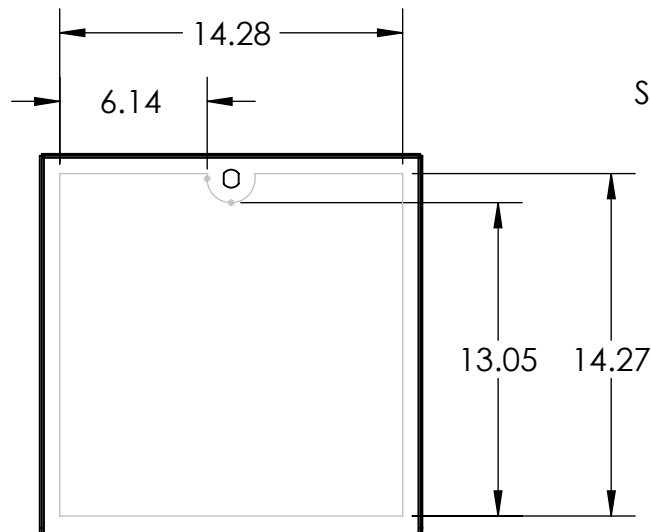

AVAILABLE CUTOUT AREA

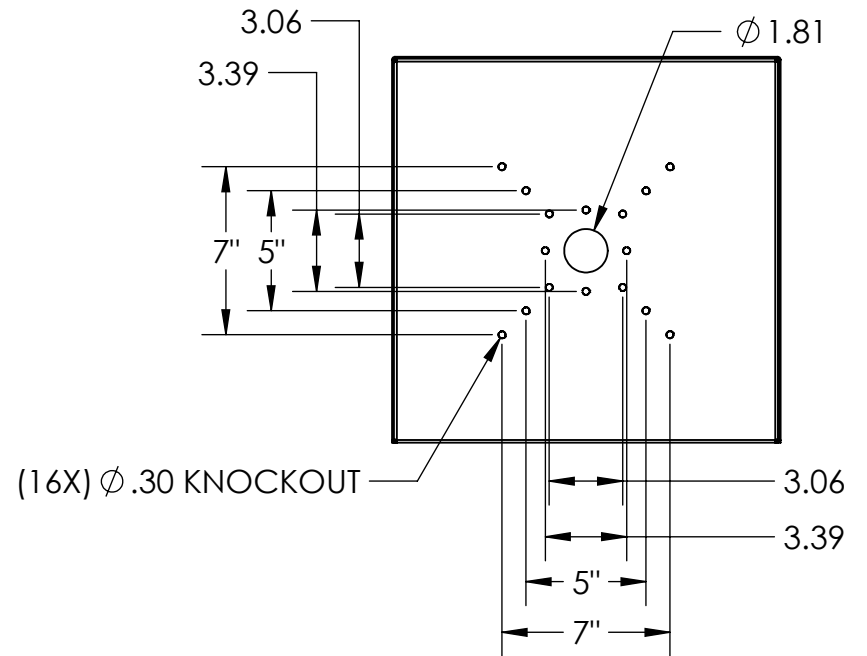

(16X) ϕ .30 KNOCKOUT

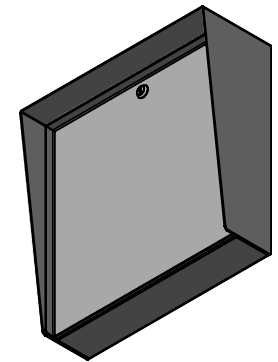

PEDESTALPRO.COM
1-800-660-3072

UNLESS OTHERWISE SPECIFIED:

DIMENSIONS ARE IN INCHES
TOLERANCES:
FRACTIONAL $\pm 1/32$
ANGULAR: $\pm 2^\circ$
TWO PLACE DECIMAL ± 0.010
THREE PLACE DECIMAL ± 0.005

INTERPRET GEOMETRIC
TOLERANCING PER:
ASME Y14.5 -2009

NAME	DATE
DRAWN	
CHECKED	

PROPRIETARY AND CONFIDENTIAL

THE INFORMATION CONTAINED IN THIS DRAWING IS THE SOLE PROPERTY OF PEDESTALPRO LLC. ANY REPRODUCTION IN PART OR AS A WHOLE WITHOUT THE WRITTEN PERMISSION OF PEDESTALPRO LLC IS PROHIBITED.

TITLE:
INSTALLATION

Tuesday, September 11, 2018 8:34:19 AM

WEIGHT:

SIZE **A** PART NO. MC-SS-16-E

NO SCALE

REV **A**

SHEET 1 OF 6

ITEM NO.	PART NUMBER	DESCRIPTION	QTY.
1	MC-SS-16-E ENCLOSURE	ENCLOSURE WELDMENT	1
2	MC-SS-16-E DOOR	DOOR WELDMENT	1
3	CAM LOCK	STRAIGHT CAM	1
4	GASKET SIDE	3/8 X .150 WEATHERSTRIPPING	2
5	GASKET TOP	3/8 X .150 WEATHERSTRIPPING	1
6	HINGE	PIANO HINGE	1
7	--	6-32 X 3/8 SS BUTTON HEAD SCREW	6
8	--	6-32 EXTERNAL TOOTH LOCK NUT	6

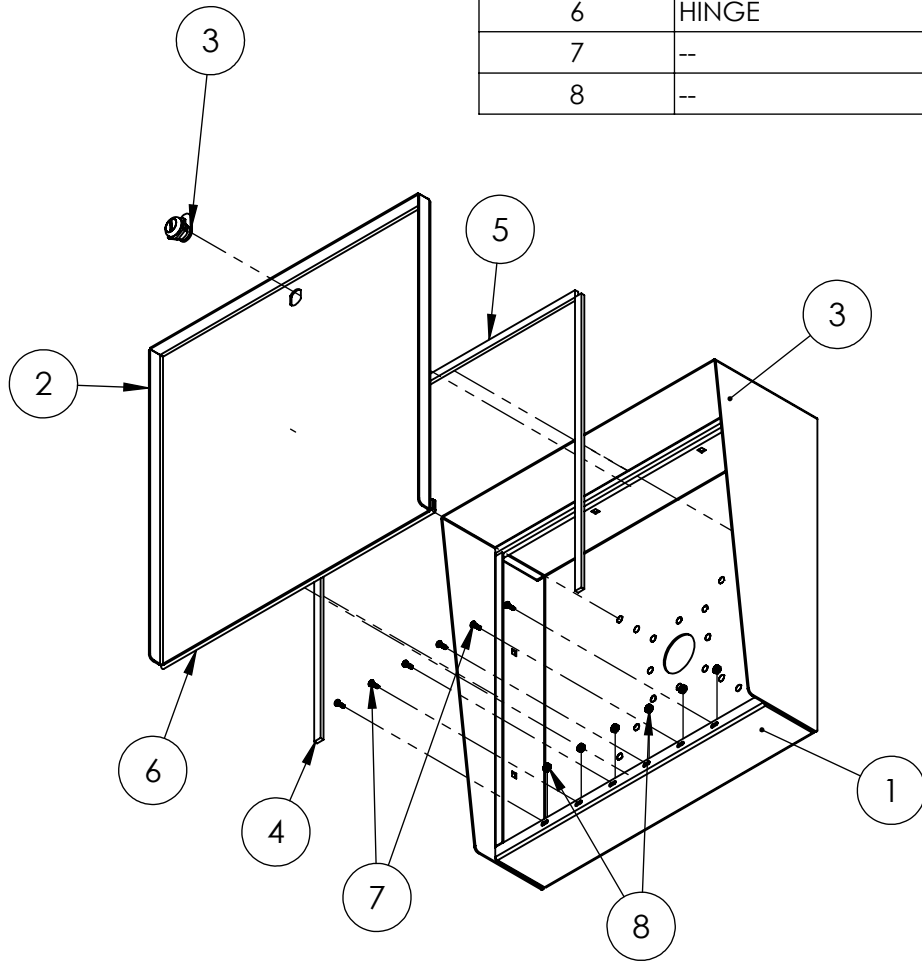

- NOTES:
- SEE STANDARD PREPARATION AND COATING INSTRUCTIONS FOR COATING PROCEDURE AND COLOR.
 - SEE STANDARD PACKAGING INSTRUCTIONS FOR PACKAGING PROCEDURE.



PEDESTALPRO.COM
1-800-660-3072

UNLESS OTHERWISE SPECIFIED:

DIMENSIONS ARE IN INCHES
TOLERANCES:
FRACTIONAL $\pm 1/32$
ANGULAR: $\pm 2^\circ$
TWO PLACE DECIMAL ± 0.010
THREE PLACE DECIMAL ± 0.005

INTERPRET GEOMETRIC
TOLERANCING PER:
ASME Y14.5 -2009

NAME	DATE
DRAWN	
CHECKED	

PROPRIETARY AND CONFIDENTIAL
THE INFORMATION CONTAINED IN THIS DRAWING IS THE SOLE PROPERTY OF PEDESTALPRO LLC. ANY REPRODUCTION IN PART OR AS A WHOLE WITHOUT THE WRITTEN PERMISSION OF PEDESTALPRO LLC IS PROHIBITED.

TITLE:
ASSEMBLY

Tuesday, September
11, 2018 8:34:19 AM

WEIGHT:

SIZE **A** PART NO.
MC-SS-16-E

NO SCALE

REV **A**

SHEET 2 OF 6