

SECTION A-A

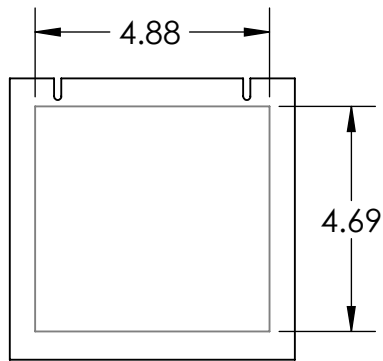

AVAILABLE CUTOUT AREA

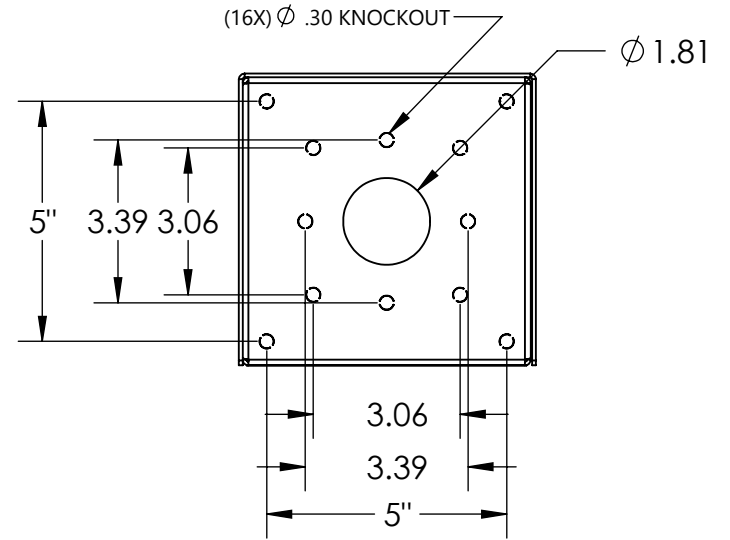
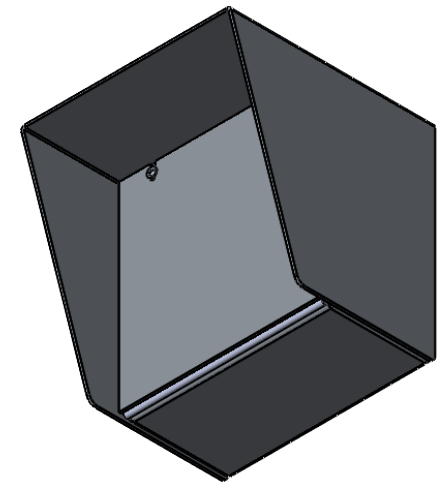

- NOTES:
 1. MATERIAL OF CONSTRUCTION IS 304 SS, BRUSHED #4.



PEDESTALPRO.COM
 1-800-660-3072

UNLESS OTHERWISE SPECIFIED:

DIMENSIONS ARE IN INCHES
 TOLERANCES:
 FRACTIONAL: $\pm 1/32$
 ANGULAR: $\pm 2^\circ$
 TWO PLACE DECIMAL ± 0.010
 THREE PLACE DECIMAL ± 0.005

INTERPRET GEOMETRIC
 TOLERANCING PER:
 ASME Y14.5 -2009

NAME	DATE
DRAWN	
CHECKED	

PROPRIETARY AND CONFIDENTIAL
 THE INFORMATION CONTAINED IN THIS DRAWING IS THE SOLE PROPERTY OF PEDESTALPRO LLC. ANY REPRODUCTION IN PART OR AS A WHOLE WITHOUT THE WRITTEN PERMISSION OF PEDESTALPRO LLC IS PROHIBITED.

TITLE:
INSTALLATION

Tuesday, September 11, 2018 8:34:19 AM

WEIGHT: 5.551

SIZE	PART NO.	REV
A	MC-SS-06-E	A
NO SCALE		SHEET 1 OF 6

ITEM NO.	PART NUMBER	DESCRIPTION	QTY.
1	MC-SS-06-E ENCLOSURE	ENCLOSURE	1
2	MC-SS-06-E DOOR	DOOR	1
3	MC-SS-06-E HOOD	HOOD	1
4	HINGE	PIANO HINGE	1
5	GASKET SIDE	3/8" X .150 WEATHERSTRIPPING	2
6	GASKET TOP	3/8" X .150 WEATHERSTRIPPING	1
7	--	6-32 PAN HEAD SCREW	4
8	--	6-32 EXTERNAL TOOTH LOCK NUT	2

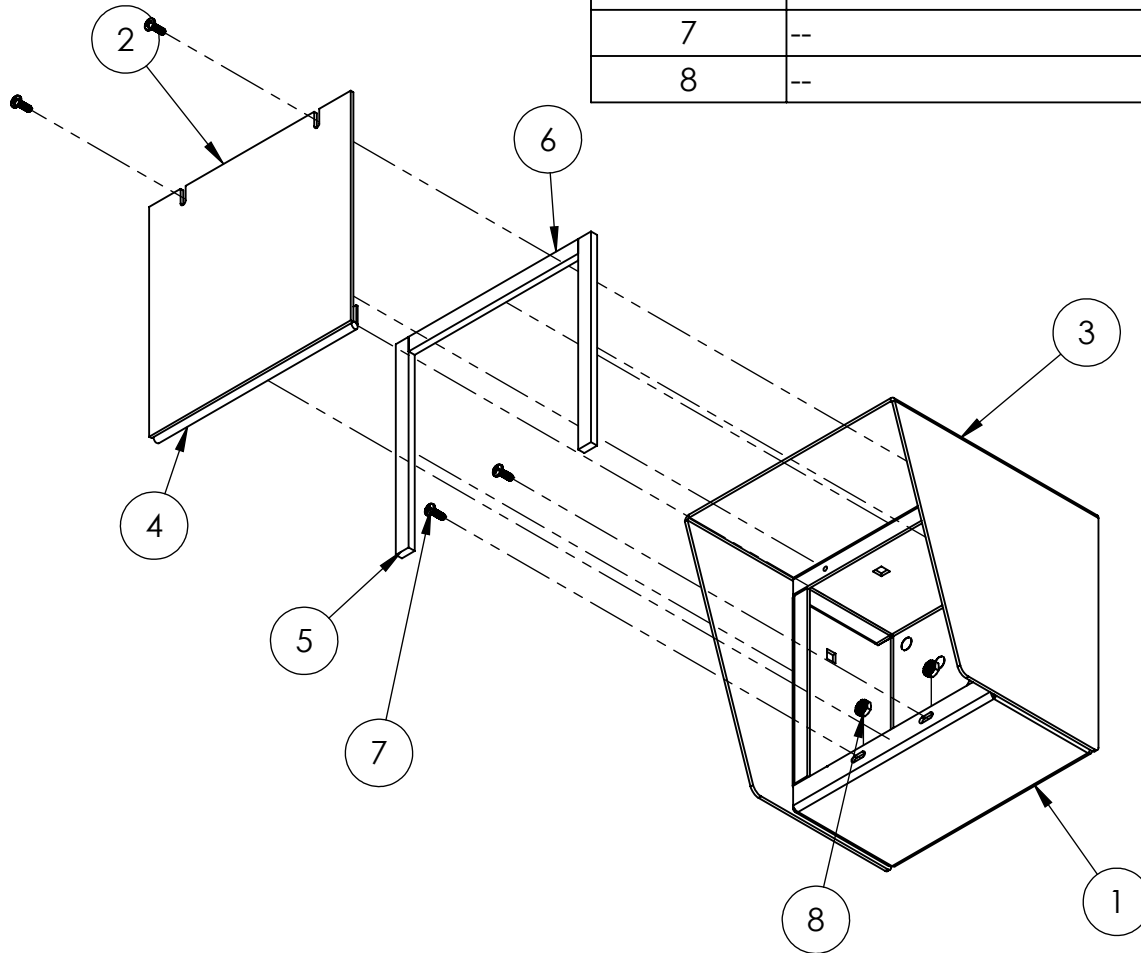

NOTES:

1. SEE STANDARD PREPARATION AND COATING INSTRUCTIONS FOR COATING PROCEDURE AND COLOR.
2. SEE STANDARD PACKAGING INSTRUCTIONS FOR PACKAGING PROCEDURE.

UNLESS OTHERWISE SPECIFIED:

DIMENSIONS ARE IN INCHES
TOLERANCES:
FRACTIONAL $\pm 1/32$
ANGULAR: $\pm 2^\circ$
TWO PLACE DECIMAL ± 0.010
THREE PLACE DECIMAL ± 0.005

INTERPRET GEOMETRIC
TOLERANCING PER:
ASME Y14.5 -2009

NAME DATE

DRAWN

CHECKED

PROPRIETARY AND CONFIDENTIAL

THE INFORMATION CONTAINED IN THIS
DRAWING IS THE SOLE PROPERTY OF
PEDESTALPRO LLC. ANY REPRODUCTION
IN PART OR AS A WHOLE WITHOUT THE
WRITTEN PERMISSION OF PEDESTALPRO LLC
IS PROHIBITED.

TITLE:

ASSEMBLY

Tuesday, September
11, 2018 8:34:19 AM

WEIGHT: 5.551

SIZE
A

PART NO.
MC-SS-06-E

REV
A

NO SCALE

SHEET 2 OF 6

PEDESTALPRO.COM
1-800-660-3072