

PRODUCT FEATURES

- Luxury aesthetics
- Antimicrobial surface
- Universal design
- Heavy duty materials
- Stainless steel construction
- Brushed #4 (180 grit)
- NDAA, Buy American, or USMCA/CUSMA compliant
- In-stock, ready-to-ship
- Available direct or through distribution
- ADA compliant

CUSTOM OPTIONS

- Customize device cutout
- Shorten or extend height
- Readily available powder coating colors (white, yellow, bronze, gray, silver)
- Choose any RAL powder color

DESCRIPTION

A stunningly beautiful bollard for high end decor in lobbies and entryways. Serves as a beautiful showcase for entry/exit buttons, ADA actuators, card readers, and more. Standing 48" tall, this remarkable pedestal comes with two (2) single gang cutouts on a flat face to receive the devices of your choice.

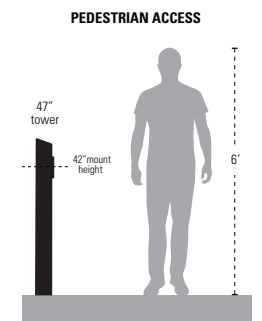

Download Pedestrian Height Chart for more details

RECOMMENDED ACCESSORIES

BOLT KIT



Stud-Anchor-500

BOLT KIT



L-Bolt-500

SHIM KIT



Shim-Kit-001

Model No. **ADA-SS-BOL-48x5RxA**

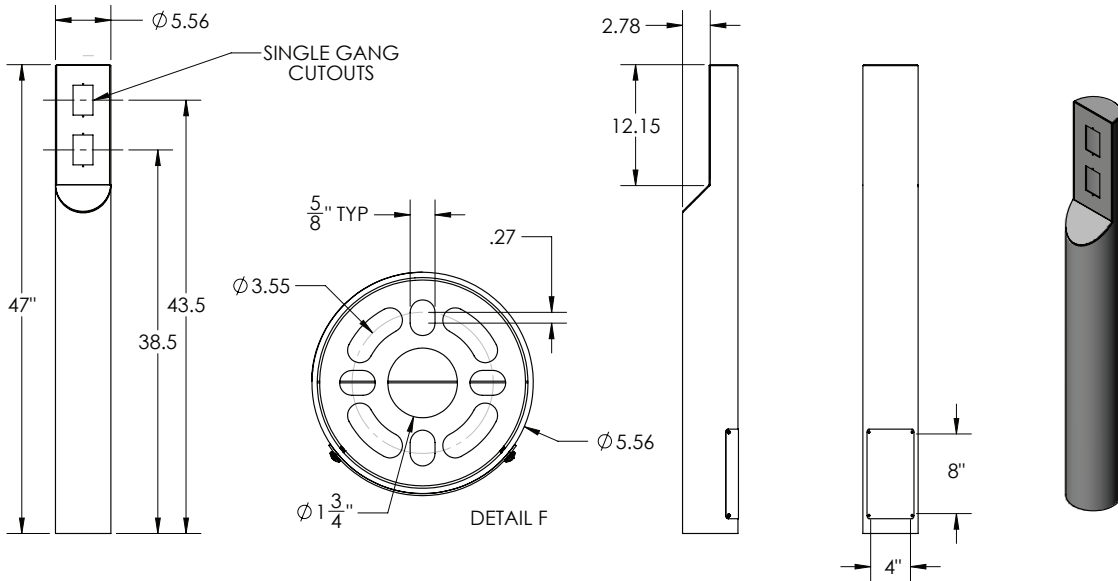

NOTE: CAD drawing available online.
Scan for more detail.



DATA & SPECS

Product Style	Bollard
Material	#304 Stainless steel
Tube	5" round x .120" wall, stainless steel #304
Face Plate	.1217" (11 gauge) stainless steel #304
Base Plate	.25" plate, stainless steel #304
Cover Plate	.0749" (14 gauge) stainless steel #304
Mounting Method	Pad mount
Pretreatment	n/a
Finish	Brushed #4 (180 grit) with mirrored corner radiuses
UV Protection	n/a
Hardware	none
Packaging	Foam wrapped and boxed individually
Package Size	52 x 8 x 6
Weight	35 lbs
Shipping Method	UPS, FedEx, or LTL freight
Compliance	NDA, Buy American, or USMCA/CUSMA (see website for details)
Warranty	1 year limited (see website for details)
Inventory Status	In-Stock (inventory levels viewable for registered users on pedestalpro.com)

SIMILAR PRODUCTS

