

NOTES:  
1. MATERIAL OF CONSTRUCTION IS 304 SS, BRUSHED #4.



PEDESTALPRO.COM  
1-800-660-3072

UNLESS OTHERWISE SPECIFIED:

DIMENSIONS ARE IN INCHES  
TOLERANCES:  
FRACTIONAL  $\pm 1/32$   
ANGULAR:  $\pm 2^\circ$   
TWO PLACE DECIMAL  $\pm 0.010$   
THREE PLACE DECIMAL  $\pm 0.005$

INTERPRET GEOMETRIC  
TOLERANCING PER:  
ASME Y14.5 -2009

NAME	DATE
DRAWN	
CHECKED	

**PROPRIETARY AND CONFIDENTIAL**  
THE INFORMATION CONTAINED IN THIS  
DRAWING IS THE SOLE PROPERTY OF  
PEDESTALPRO LLC. ANY REPRODUCTION  
IN PART OR AS A WHOLE WITHOUT THE  
WRITTEN PERMISSION OF PEDESTALPRO LLC  
IS PROHIBITED.

TITLE:  
**INSTALLATION**

Monday, November  
30, 2020 3:50:00 PM

WEIGHT: 73.500

SIZE	PART NO.	REV
<b>A</b>	84TOW-2NIP-01-304	<b>A</b>

NO SCALE

SHEET 1 OF 8

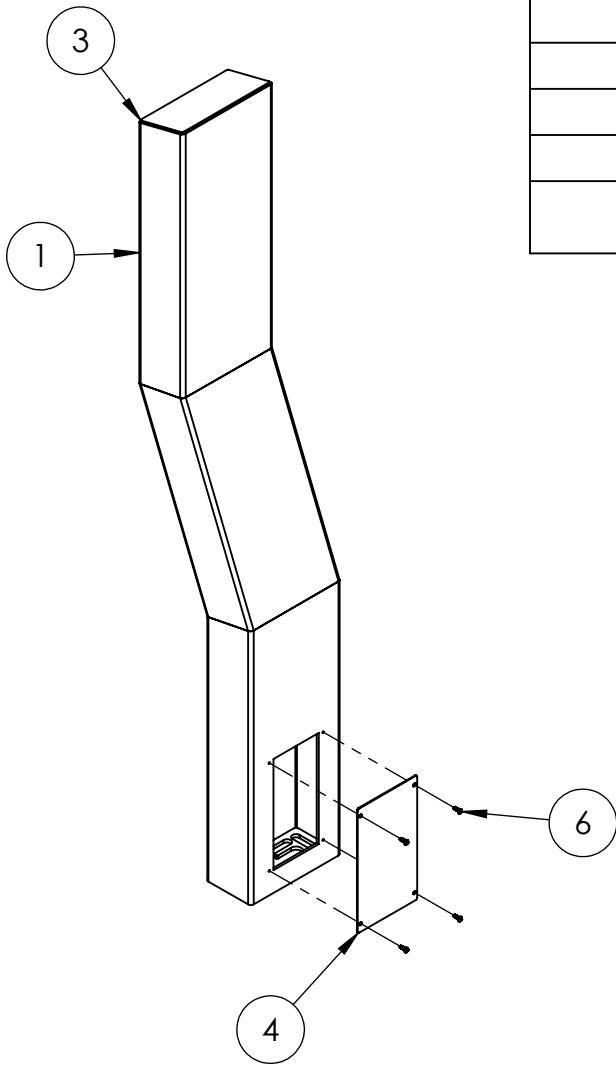

ITEM NO.	PART NUMBER	DESCRIPTION	QTY.
1	84TOW-2NIP-01-304	8X4 WELDMENT	1
2	PLTBAS-84-84	STANDARD BASE PLATE	1
3	PLTCAP-84-84-30	84-30 STANDARD CAP PLATE	1
4	PLTACC-510	STANDARD ACCESS COVER	1
5	PLT-IP2N-STANDOFF	IP2N STANDOFF	2
6	--	8-32 X 1/2" PAN HEAD SCREW	4
8	IP 2N VERSO (DUAL)		1

NOTES:

1. SEE STANDARD PREPARATION AND COATING INSTRUCTIONS FOR COATING PROCEDURE AND COLOR.
2. SEE STANDARD PACKAGING INSTRUCTIONS FOR PACKAGING PROCEDURE.

PEDESTALPRO.COM  
1-800-660-3072

UNLESS OTHERWISE SPECIFIED:

DIMENSIONS ARE IN INCHES  
TOLERANCES:  
FRACTIONAL  $\pm 1/32$   
ANGULAR:  $\pm 2^\circ$   
TWO PLACE DECIMAL  $\pm 0.010$   
THREE PLACE DECIMAL  $\pm 0.005$

INTERPRET GEOMETRIC  
TOLERANCING PER:  
ASME Y14.5 -2009

NAME	DATE
DRAWN	
CHECKED	

**PROPRIETARY AND CONFIDENTIAL**  
THE INFORMATION CONTAINED IN THIS  
DRAWING IS THE SOLE PROPERTY OF  
PEDESTALPRO LLC. ANY REPRODUCTION  
IN PART OR AS A WHOLE WITHOUT THE  
WRITTEN PERMISSION OF PEDESTALPRO LLC  
IS PROHIBITED.

TITLE:  
**ASSEMBLY**

Monday, November  
30, 2020 3:50:00 PM

WEIGHT: 73.500

SIZE <b>A</b>	PART NO. 84TOW-2NIP-01-304
------------------	-------------------------------

NO SCALE

REV <b>A</b>
-----------------

SHEET 2 OF 8