

- NOTES:
1. MOUNTS THE FOLLOWING CONTROL 4 MODELS:
C4-DS2FM AND C4-DS2FMKP
 2. 2N MODELS: VERSO 3 MODULE



PEDESTALPRO.COM
1-800-660-3072

UNLESS OTHERWISE SPECIFIED:
DIMENSIONS ARE IN INCHES
TOLERANCES:
FRACTIONAL $\pm 1/32$
ANGULAR: $\pm 2^\circ$
TWO PLACE DECIMAL ± 0.010
THREE PLACE DECIMAL ± 0.005

INTERPRET GEOMETRIC
TOLERANCING PER:
ASME Y14.5 -2009

| NAME | DATE |
|------|------|
| | |
| | |

DRAWN
CHECKED
PROPRIETARY AND CONFIDENTIAL
THE INFORMATION CONTAINED IN THIS DRAWING IS THE SOLE PROPERTY OF PEDESTALPRO LLC. ANY REPRODUCTION IN PART OR AS A WHOLE WITHOUT THE WRITTEN PERMISSION OF PEDESTALPRO LLC IS PROHIBITED.

| | | | | | |
|-------------------------------|--|---|-------------------|---------------------------------|------------------|
| TITLE: INSTALLATION | | DATE: Tuesday, September 11, 2018 9:34:19 AM | SIZE: A | PART NO.: 818HOU-PRO-001-304 | REV: A |
| WEIGHT: | | NO SCALE | SHEET 1 OF 8 | | |

| ITEM NO. | PART NUMBER | DESCRIPTION | QTY. |
|----------|------------------------------|---------------------------------|------|
| 1 | 814HOU-PED-001-304 ENCLOSURE | ENCLOSURE WELDMENT | 1 |
| 2 | 818HOU-PRO-001-304 DOOR | DOOR WELDMENT | 1 |
| 3 | 818HOU-PRO-001-304 DOOR 2 | DOOR 2 WELDMENT | 1 |
| 4 | CAM LOCK | STRAIGHT CAM | 1 |
| 5 | GASKET SIDE | 3/8 X .150 WEATHERSTRIPPING | 2 |
| 6 | GASKET TOP | 3/8 X .150 WEATHERSTRIPPING | 1 |
| 7 | HINGE | PIANO HINGE | 1 |
| 8 | -- | 6-32 X 3/8 SS BUTTON HEAD SCREW | 4 |
| 9 | -- | 6-32 EXTERNAL TOOTH LOCK NUT | 4 |

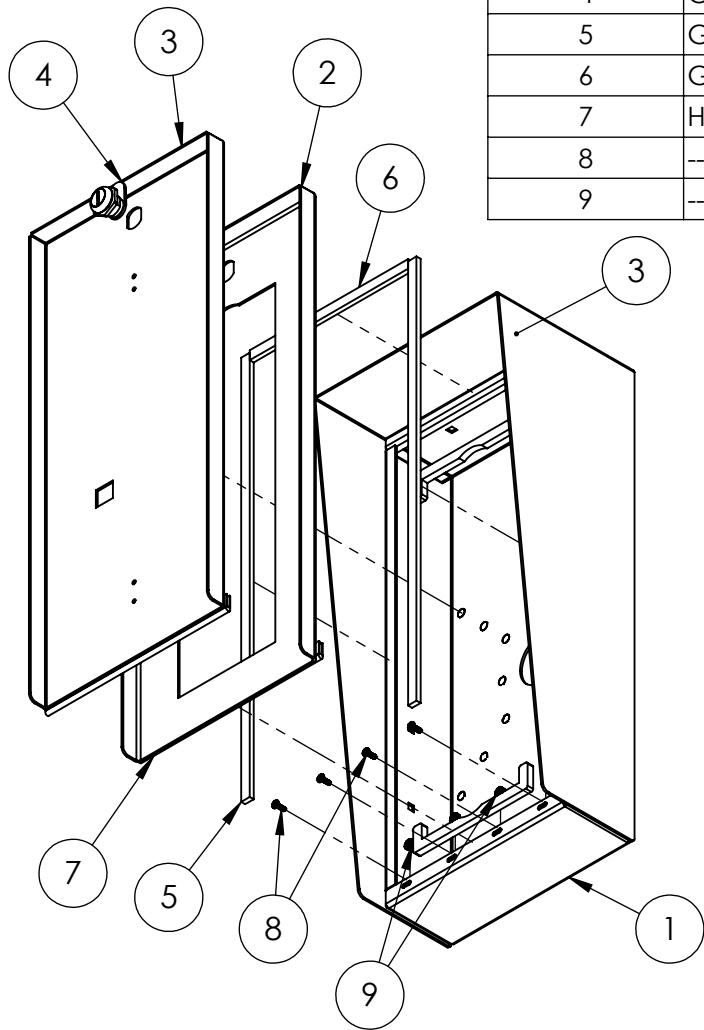

NOTES:

1. SEE STANDARD PREPARATION AND COATING INSTRUCTIONS FOR COATING PROCEDURE AND COLOR.
2. SEE STANDARD PACKAGING INSTRUCTIONS FOR PACKAGING PROCEDURE.



PEDESTALPRO.COM
1-800-660-3072

UNLESS OTHERWISE SPECIFIED:

DIMENSIONS ARE IN INCHES
TOLERANCES:
FRACTIONAL $\pm 1/32$
ANGULAR: $\pm 2^\circ$
TWO PLACE DECIMAL ± 0.010
THREE PLACE DECIMAL ± 0.005

INTERPRET GEOMETRIC
TOLERANCING PER:
ASME Y14.5 -2009

| NAME | DATE |
|---------|------|
| DRAWN | |
| CHECKED | |

PROPRIETARY AND CONFIDENTIAL

THE INFORMATION CONTAINED IN THIS DRAWING IS THE SOLE PROPERTY OF PEDESTALPRO LLC. ANY REPRODUCTION IN PART OR AS A WHOLE WITHOUT THE WRITTEN PERMISSION OF PEDESTALPRO LLC IS PROHIBITED.

TITLE:
ASSEMBLY

Tuesday, September
11, 2018 9:34:19 AM

WEIGHT:

SIZE **A** PART NO.
818HOU-PRO-001-304

NO SCALE

REV **A**

SHEET 2 OF 8