

SECTION A-A

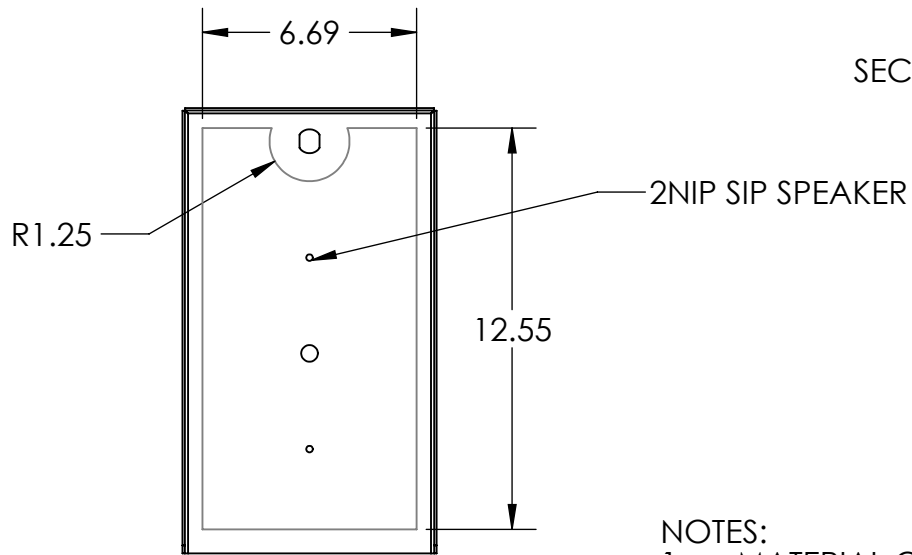
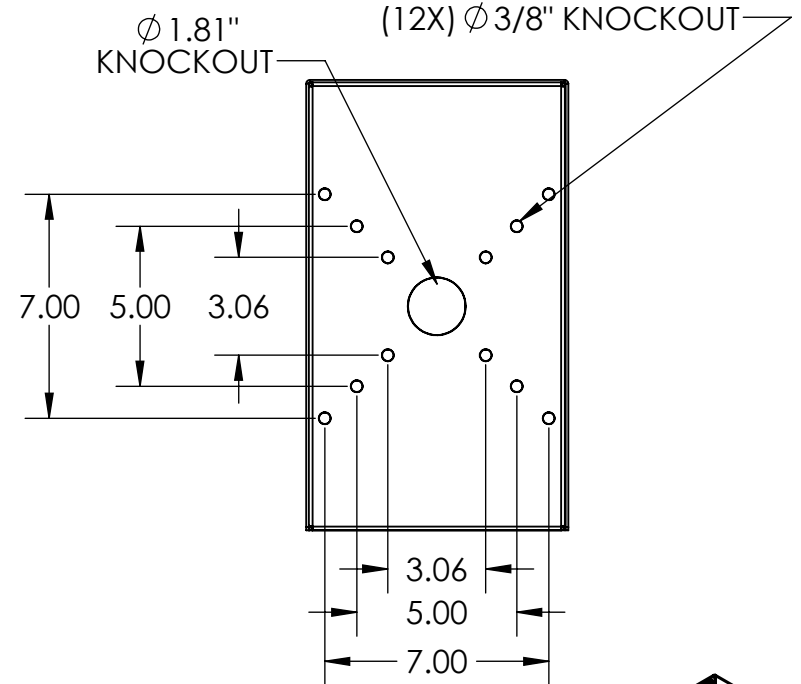

AVAILABLE CUTOUT AREA

NOTES:

- MATERIAL OF CONSTRUCTION IS 304 SS, BRUSHED #4.

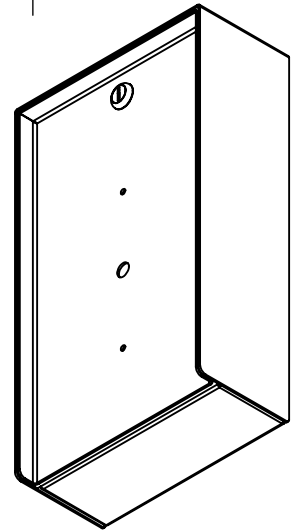

PEDESTALPRO.COM
1-800-660-3072

UNLESS OTHERWISE SPECIFIED:

DIMENSIONS ARE IN INCHES
TOLERANCES:
FRACTIONAL $\pm 1/32$
ANGULAR: $\pm 2^\circ$
TWO PLACE DECIMAL ± 0.010
THREE PLACE DECIMAL ± 0.005

INTERPRET GEOMETRIC
TOLERANCING PER:
ASME Y14.5 -2009

| NAME | DATE |
|---------|------|
| DRAWN | |
| CHECKED | |

PROPRIETARY AND CONFIDENTIAL
THE INFORMATION CONTAINED IN THIS DRAWING IS THE SOLE PROPERTY OF PEDESTALPRO LLC. ANY REPRODUCTION IN PART OR AS A WHOLE WITHOUT THE WRITTEN PERMISSION OF PEDESTALPRO LLC IS PROHIBITED.

TITLE:
INSTALLATION

Wednesday, April 26, 2023
11:04:21 AM

WEIGHT: 12.219

| SIZE | PART NO. | REV |
|----------|--------------------|--------------|
| A | 814HOU-2NIP-03-304 | A |
| NO SCALE | | SHEET 1 OF 6 |

| ITEM NO. | PART NUMBER | DESCRIPTION | QTY. |
|----------|------------------------------|------------------------------|------|
| 1 | 814HOU-2NIP-03-304 ENCLOSURE | ENCLOSURE WELDMENT | 1 |
| 2 | 814HOU-2NIP-03-304 DOOR | DOOR WELDMENT | 1 |
| 3 | 814HOU-2NIP-03-304 HOOD | HOOD | 1 |
| 4 | HINGE | PIANO HINGE | 1 |
| 5 | CAM LOCK | STRAIGHT CAM | 1 |
| 6 | GASKET SIDE | 3/8" X .150 WEATHERSTRIPPING | 2 |
| 7 | GASKET TOP | 3/8" X .150 WEATHERSTRIPPING | 1 |
| 8 | -- | 6-32 PAN HEAD SCREW | 4 |
| 9 | -- | 6-32 EXTERNAL TOOTH LOCK NUT | 4 |

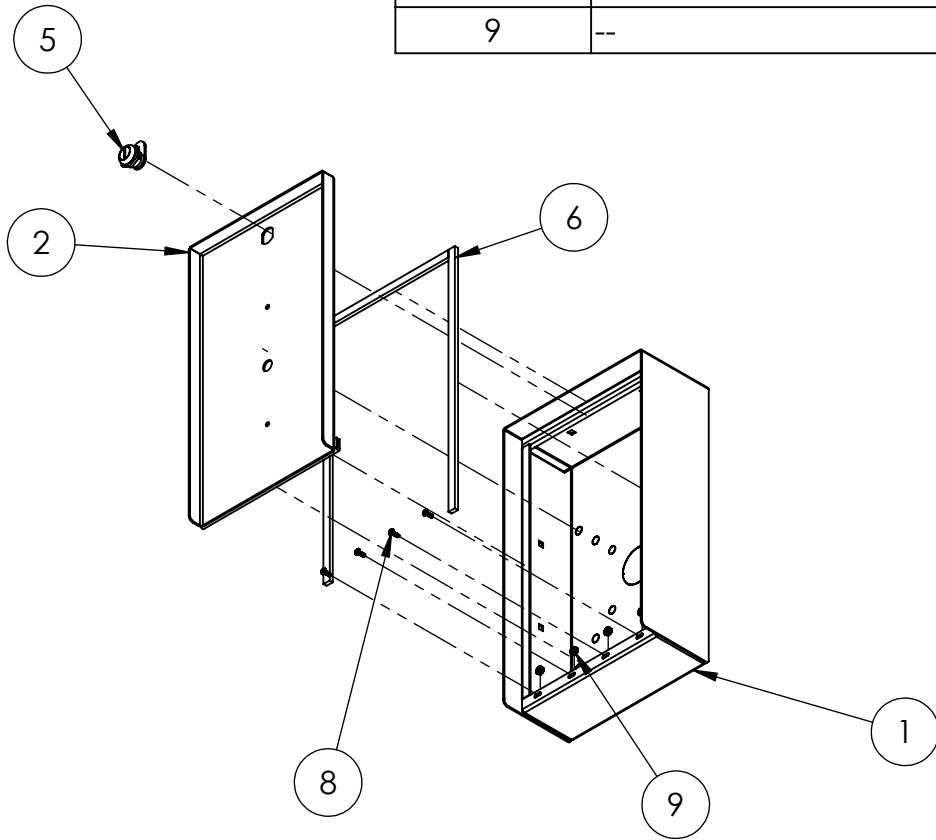

NOTES:

- SEE STANDARD PREPARATION AND COATING INSTRUCTIONS FOR COATING PROCEDURE AND COLOR.
- SEE STANDARD PACKAGING INSTRUCTIONS FOR PACKAGING PROCEDURE.



PEDESTALPRO.COM
1-800-660-3072

UNLESS OTHERWISE SPECIFIED:

DIMENSIONS ARE IN INCHES
TOLERANCES:
FRACTIONAL $\pm 1/32$
ANGULAR: $\pm 2^\circ$
TWO PLACE DECIMAL ± 0.010
THREE PLACE DECIMAL ± 0.005

INTERPRET GEOMETRIC
TOLERANCING PER:
ASME Y14.5 -2009

| NAME | DATE |
|---------|------|
| DRAWN | |
| CHECKED | |

PROPRIETARY AND CONFIDENTIAL

THE INFORMATION CONTAINED IN THIS DRAWING IS THE SOLE PROPERTY OF PEDESTALPRO LLC. ANY REPRODUCTION IN PART OR AS A WHOLE WITHOUT THE WRITTEN PERMISSION OF PEDESTALPRO LLC IS PROHIBITED.

TITLE:

ASSEMBLY

Wednesday, April 26, 2023
11:04:21 AM

WEIGHT: 12.219

| SIZE | PART NO. | REV |
|----------|--------------------|--------------|
| A | 814HOU-2NIP-03-304 | A |
| NO SCALE | | SHEET 2 OF 6 |