

SECTION A-A

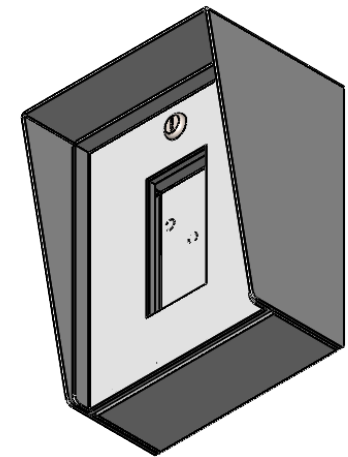

- NOTES:
1. MATERIAL OF CONSTRUCTION IS MILD STEEL.
 2. 2-4 MILS BLACK WRINKLE POWDER COAT.

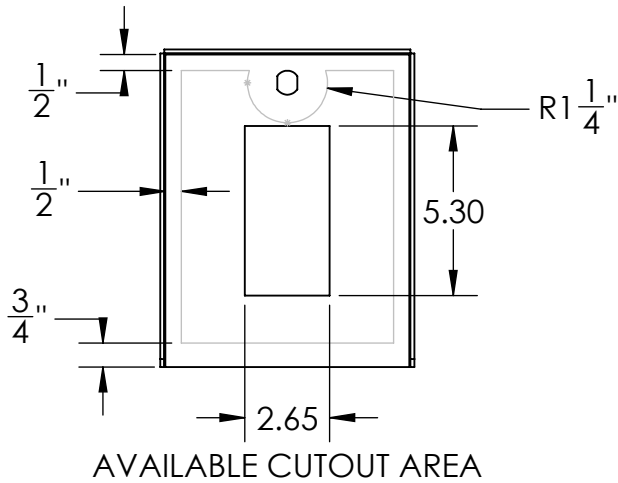
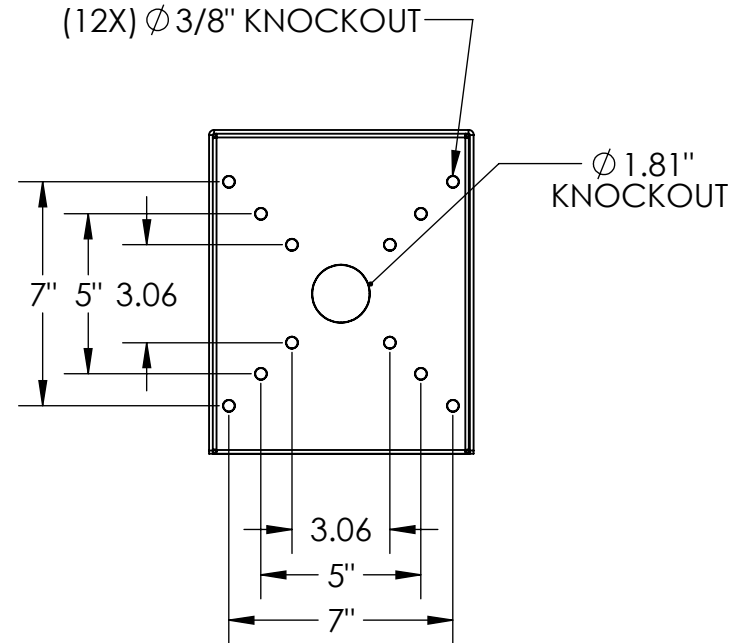

PEDESTALPRO.COM
1-800-660-3072

UNLESS OTHERWISE SPECIFIED:

DIMENSIONS ARE IN INCHES
TOLERANCES:
FRACTIONAL $\pm 1/32$
ANGULAR: $\pm 2^\circ$
TWO PLACE DECIMAL ± 0.010
THREE PLACE DECIMAL ± 0.005

INTERPRET GEOMETRIC
TOLERANCING PER:
ASME Y14.5 -2009

| NAME | DATE |
|---------|------|
| DRAWN | |
| CHECKED | |

PROPRIETARY AND CONFIDENTIAL

THE INFORMATION CONTAINED IN THIS DRAWING IS THE SOLE PROPERTY OF PEDESTALPRO LLC. ANY REPRODUCTION IN PART OR AS A WHOLE WITHOUT THE WRITTEN PERMISSION OF PEDESTALPRO LLC IS PROHIBITED.

TITLE:
INSTALLATION

Monday, August 29,
2022 10:46:36 AM

WEIGHT: 12.524

| SIZE | PART NO. | REV |
|----------|--------------------|--------------|
| A | 810HOU-DOOR-01-CRS | A |
| NO SCALE | | SHEET 1 OF 7 |

| ITEM NO. | PART NUMBER | DESCRIPTION | QTY. |
|----------|------------------------------|------------------------------|------|
| 1 | 810HOU-DOOR-01-CRS ENCLOSURE | ENCLOSURE WELDMENT | 1 |
| 2 | HINGE | PIANO HINGE | 1 |
| 3 | 810HOU-DOOR-01-CRS DOOR | DOOR WELDMENT | 1 |
| 4 | 810HOU-DOOR-01-CRS HOOD | HOOD WELDMENT | 1 |
| 5 | CAM LOCK | STRAIGHT CAM | 1 |
| 6 | GASKET SIDE | 3/8" X .150 WEATHERSTRIPPING | 2 |
| 7 | GASKET TOP | 3/8" X .150 WEATHERSTRIPPING | 1 |
| 8 | -- | 6-32 PAN HEAD SCREW | 4 |
| 9 | -- | 6-32 EXTERNAL TOOTH LOCK NUT | 4 |
| 10 | 810HOU-DOOR-01-CRS BRACKET | MOUNTING BRACKET | 1 |

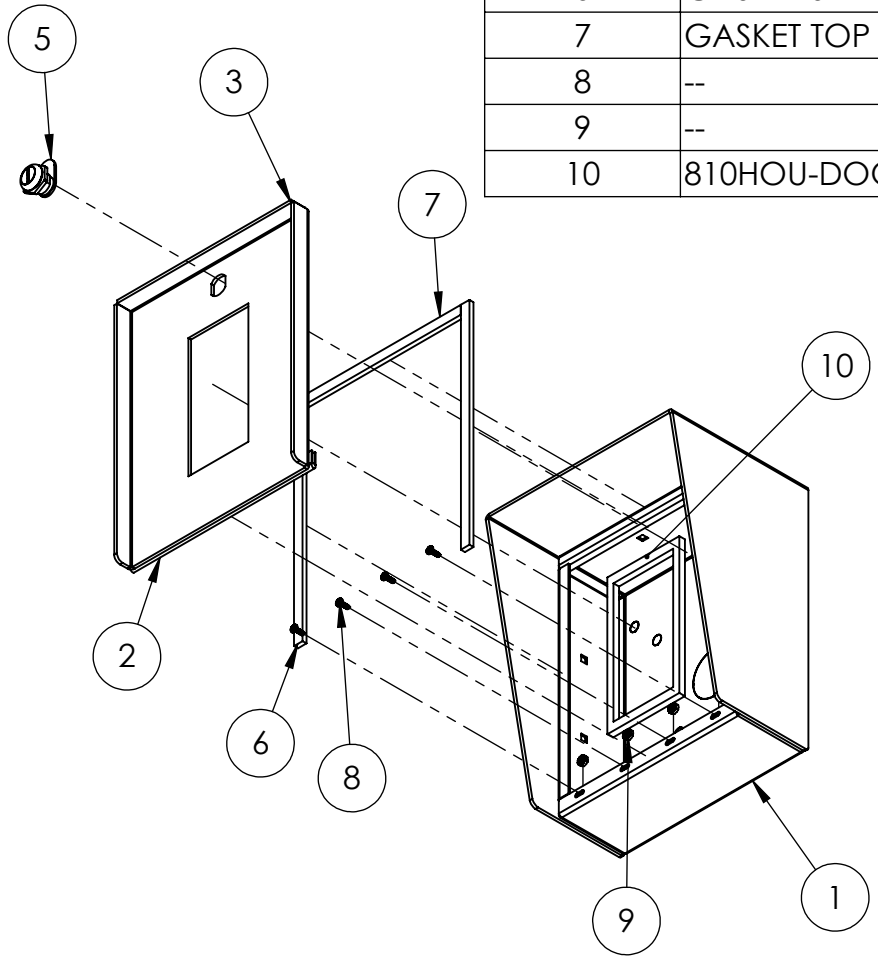

NOTES:

1. SEE STANDARD PREPARATION AND COATING INSTRUCTIONS FOR COATING PROCEDURE AND COLOR.
2. SEE STANDARD PACKAGING INSTRUCTIONS FOR PACKAGING PROCEDURE.



PEDESTALPRO.COM
1-800-660-3072

UNLESS OTHERWISE SPECIFIED:

DIMENSIONS ARE IN INCHES
TOLERANCES:
FRACTIONAL $\pm 1/32$
ANGULAR: $\pm 2^\circ$
TWO PLACE DECIMAL ± 0.010
THREE PLACE DECIMAL ± 0.005

INTERPRET GEOMETRIC TOLERANCING PER: ASME Y14.5 -2009

| NAME | DATE |
|---------|------|
| DRAWN | |
| CHECKED | |

PROPRIETARY AND CONFIDENTIAL
THE INFORMATION CONTAINED IN THIS DRAWING IS THE SOLE PROPERTY OF PEDESTALPRO LLC. ANY REPRODUCTION IN PART OR AS A WHOLE WITHOUT THE WRITTEN PERMISSION OF PEDESTALPRO LLC IS PROHIBITED.

TITLE:
ASSEMBLY

Monday, August 29, 2022 10:46:36 AM

WEIGHT: 12.524

| SIZE | PART NO. | REV |
|----------|--------------------|----------|
| A | 810HOU-DOOR-01-CRS | A |

NO SCALE

SHEET 2 OF 7