

2N ACCESS UNIT M
SURFACE MOUNT

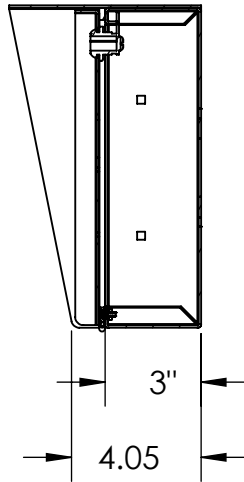

SECTION A-A

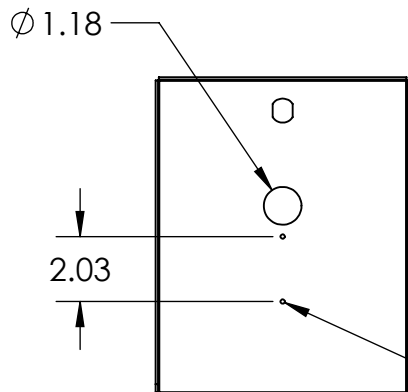
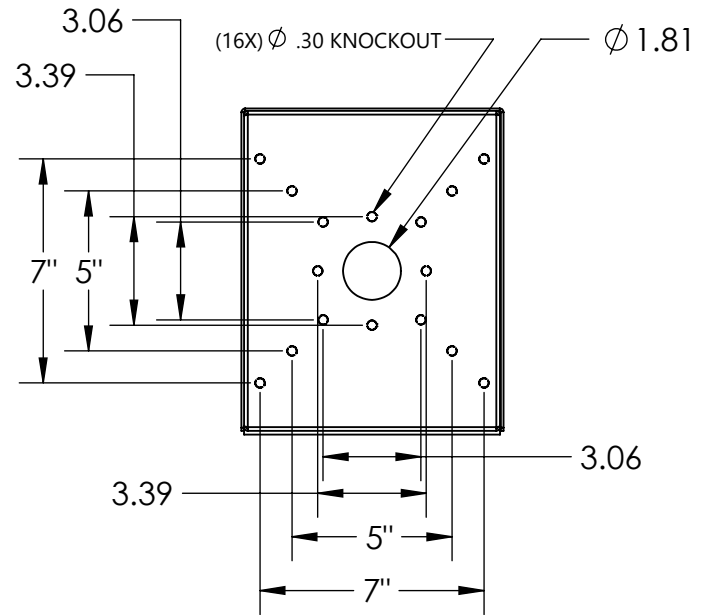

(2X)DRILL #29
TAP 8-32

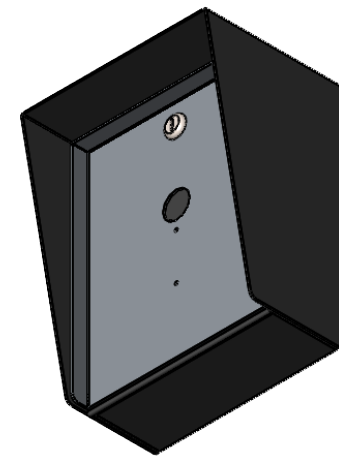

NOTES:

1. MATERIAL OF CONSTRUCTION IS 304 SS, BRUSHED #4.



PEDESTALPRO.COM
1-800-660-3072

UNLESS OTHERWISE SPECIFIED:

DIMENSIONS ARE IN INCHES
TOLERANCES:
FRACTIONAL $\pm 1/32$
ANGULAR: $\pm 2^\circ$
TWO PLACE DECIMAL ± 0.010
THREE PLACE DECIMAL ± 0.005

INTERPRET GEOMETRIC
TOLERANCING PER:
ASME Y14.5 -2009

NAME	DATE
DRAWN	
CHECKED	

PROPRIETARY AND CONFIDENTIAL
THE INFORMATION CONTAINED IN THIS
DRAWING IS THE SOLE PROPERTY OF
PEDESTALPRO LLC. ANY REPRODUCTION
IN PART OR AS A WHOLE WITHOUT THE
WRITTEN PERMISSION OF PEDESTALPRO LLC
IS PROHIBITED.

TITLE:
INSTALLATION

Tuesday, September
11, 2018 9:34:19 AM

WEIGHT:

SIZE	PART NO.	REV
A	810HOU-2NIP-010-304	A
NO SCALE		SHEET 1 OF 6

ITEM NO.	PART NUMBER	DESCRIPTION	QTY.
1	810HOU-2NIP-010-304 ENCLOSURE	ENCLOSURE	1
2	810HOU-2NIP-010-304 DOOR	DOOR	1
3	810HOU-2NIP-010-304 HOOD	HOOD	1
4	HINGE	PIANO HINGE	1
5	CAM LOCK	Straight Cam	1
6	GASKET SIDE	3/8 X .150 WATHERSTRIPPING	2
7	GASKET TOP	3/8 X .150 WATHERSTRIPPING	1
8	--	6-32 X 3/8 SS BUTTON HEAD SCREW	3
9	--	6-32 EXTERNAL TOOTH LOCK NUT	3

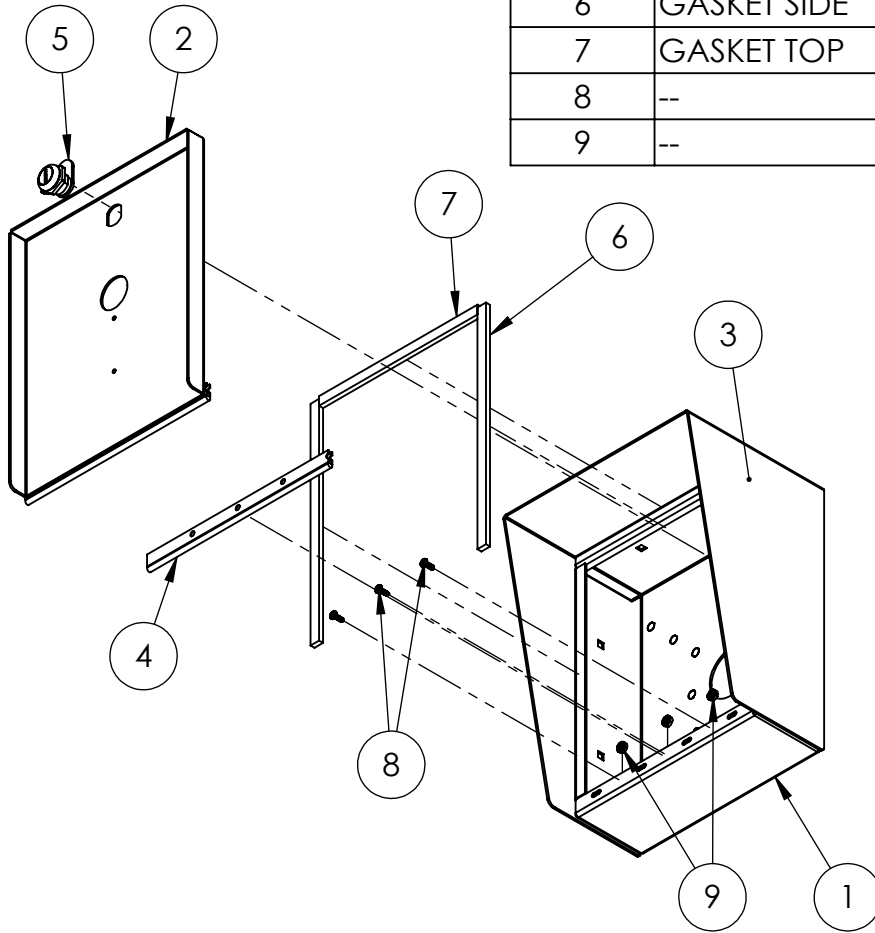

NOTES:

1. SEE STANDARD PREPARATION AND COATING INSTRUCTIONS FOR COATING PROCEDURE AND COLOR.
2. SEE STANDARD PACKAGING INSTRUCTIONS FOR PACKAGING PROCEDURE.



PEDESTALPRO.COM
1-800-660-3072

UNLESS OTHERWISE SPECIFIED:

DIMENSIONS ARE IN INCHES
TOLERANCES:
FRACTIONAL $\pm 1/32$
ANGULAR: $\pm 2^\circ$
TWO PLACE DECIMAL ± 0.010
THREE PLACE DECIMAL ± 0.005

INTERPRET GEOMETRIC
TOLERANCING PER:
ASME Y14.5 -2009

NAME DATE

DRAWN

CHECKED

PROPRIETARY AND CONFIDENTIAL

THE INFORMATION CONTAINED IN THIS
DRAWING IS THE SOLE PROPERTY OF
PEDESTALPRO LLC. ANY REPRODUCTION
IN PART OR AS A WHOLE WITHOUT THE
WRITTEN PERMISSION OF PEDESTALPRO LLC
IS PROHIBITED.

TITLE:

ASSEMBLY

Tuesday, September
11, 2018 9:34:19 AM

WEIGHT:

SIZE
A

PART NO.
810HOU-2NIP-010-304

REV
A

NO SCALE

SHEET 2 OF 6