

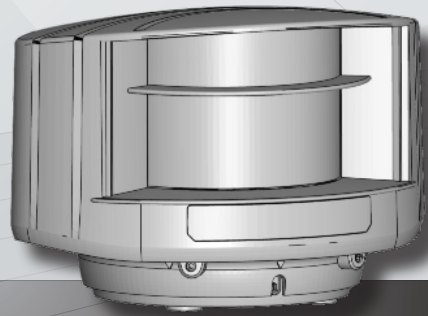

EN



LZR[®]-S600

LASER SCANNER FOR BUILDING AUTOMATION & SECURITY
with max. detection range of 82 ft x 82 ft

User's Guide



Visit website for
available languages of
this document.



READ BEFORE BEGINNING INSTALLATION/PROGRAMMING/SET-UP

SAFETY

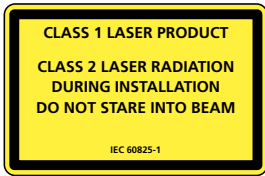

The device emits invisible (IR) and visible laser radiation.

IR laser: wavelength 905nm; output power 0.10mW
(Class 1 according to IEC 60825-1)

Visible laser: wavelength 635nm; output power 0.95mW
(Class 2 according to IEC 60825-1)

The visible laser beams are inactive during normal operation.
The installer can activate the visible lasers if needed.

Do not stare into visible laser beams.



CAUTION!

Use of controls, adjustments, or performance of procedures other than those specified herein may result in hazardous radiation exposure.

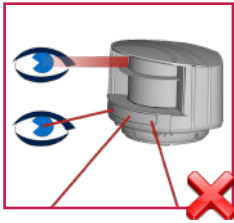

Do not look into the laser emitter or the visible red laser beams.

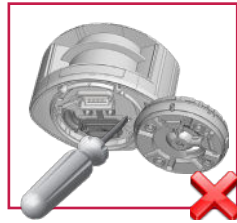

The warranty is void if unauthorized repairs are made or attempted by unauthorized personnel.



Only trained and qualified personnel are recommended to install and set up the sensor.

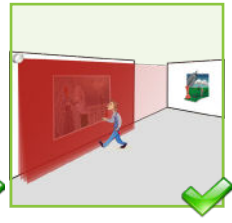

Test the proper operation of the installation before leaving the premises.

INSTALLATION AND MAINTENANCE



Avoid extreme vibrations.



Do not cover the laser windows.

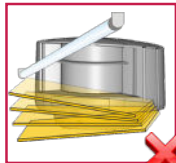

Avoid moving objects and light sources in front of the laser window.



Avoid the presence of smoke and fog in the detection field.



Avoid condensation on the laser windows.

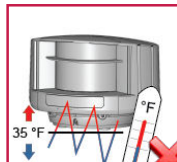

Avoid exposure to sudden and extreme temperature changes.



Avoid direct exposure to high pressure cleaning.



Do not use aggressive products to clean the laser windows.



Clean the laser window with compressed air. If needed, wipe only with a soft, clean and damp microfibre cloth.

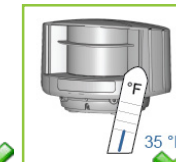

Keep the sensor permanently powered in environments where the temperature can drop below 35 °F.

READ BEFORE BEGINNING INSTALLATION/PROGRAMMING/SET-UP

DESCRIPTION

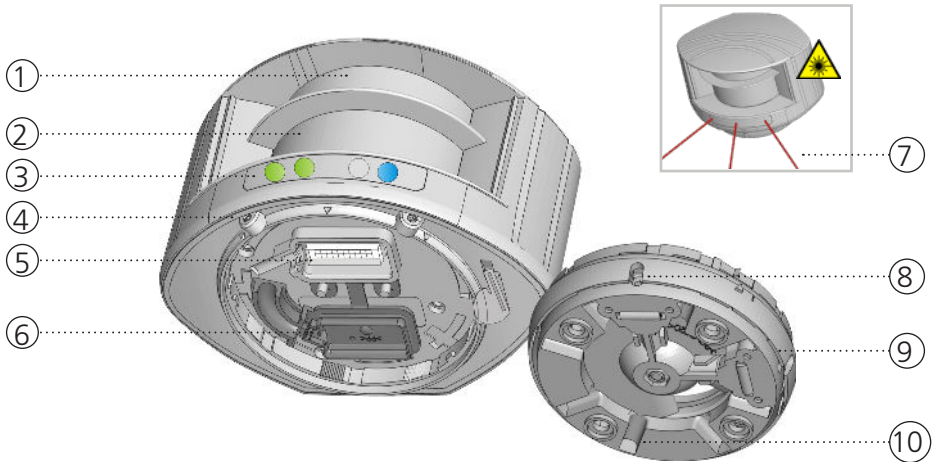

- | | |
|---------------------------------|--|
| 1. laser window – emission | 6. protection cover |
| 2. laser window – reception | 7. visible laser beams (3) |
| 3. LED signals (4) | 8. notches for tilt angle adjustment (2) |
| 4. screws for position lock (2) | 9. adjustable bracket |
| 5. connector | 10. cable conduits (4) |

LED SIGNAL

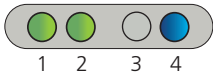

1. Detection LED: R1 – opening field
2. Detection LED: R2 – safety field
3. Error LED
4. Power LED

- LED flashes quickly
- LED flashes
- LED flashes slowly
- LED is off

DETECTION LEDs

- detection (red)
- no detection (green)

ERROR LED

- error (orange)
- no error (off)

POWER LED

- power (blue)
- no power (on)



All 4 LEDs can be switched off and on again by remote control. This can be useful in cases where the sensor should not draw any attention.



SYMBOLS

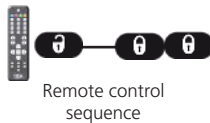

READ BEFORE BEGINNING INSTALLATION/PROGRAMMING/SET-UP

HOW TO USE THE REMOTE CONTROL



After unlocking, the red LED flashes and the sensor can be adjusted by remote control.



If the red LED flashes quickly after unlocking, you need to enter an access code from 1 to 4 digits.



To end an adjustment session, always lock the sensor.

ADJUSTING ONE OR MORE PARAMETERS



CHECKING A VALUE

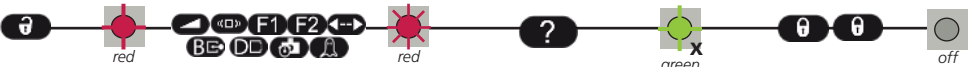

green 4 orange 1 green 2 = field width: 4.2 m

orange 3 = field width is defined by Learn

X = NUMBER OF FLASHES = VALUE OF THE PARAMETER

RESTORING TO FACTORY VALUES

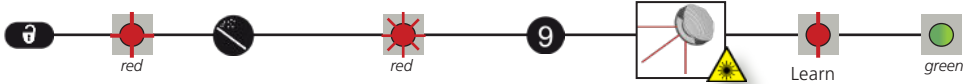

SAVING AN ACCESS CODE

The access code is recommended for sensors installed close to each other.



DELETING AN ACCESS CODE

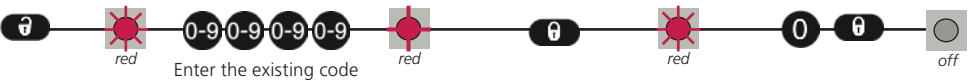

Enter the existing code



30 minutes after last use, the sensor locks access to the remote control session. To regain access, cycle the power. The remote control session will then be accessible for another 30 minutes.



PROTECTION OF WORKS OF ART: WARNING & ALARM

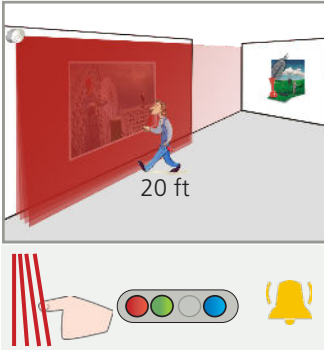

Field 1 (4 active curtains) triggers relay 1:
WARNING

Adapt the field widths (ex: 20 ft):



Reduce field 2 to one curtain (C1):

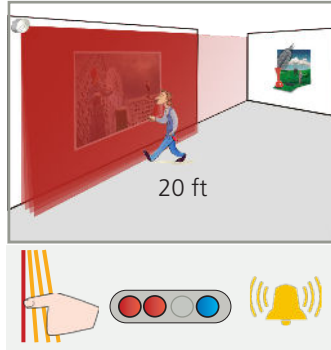

Field 2 (only curtain C1 active) triggers relay 2:
ALARM

DAY AND NIGHT FEATURE

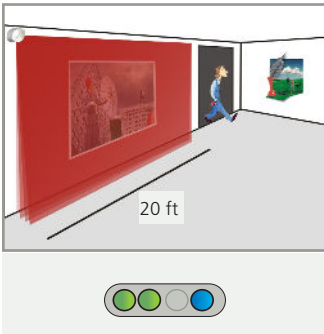

During day time, only field 1 is active and triggers relay 1.

Adapt the field width of field 1 (ex: 20 ft):



Adapt the field width of field 2 (ex: 25 ft):

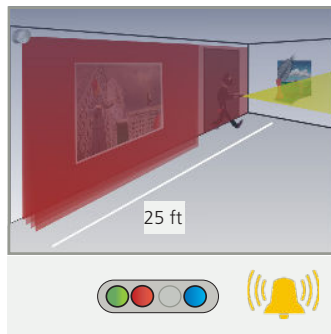

During night time, field 2 is active as well and triggers relay 2 (intrusion alarm).

1 MOUNTING

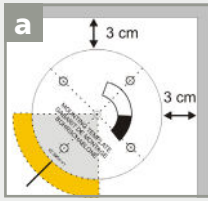

Use the mounting template to position the sensor correctly. The gray area indicates the detection range.

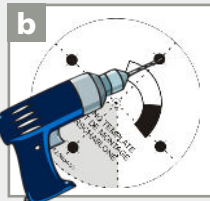

Drill 4 holes as indicated on the mounting template. Drill a hole (1/2 inch min.) for the cable if possible.

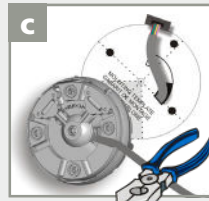

Pass the cable ± 4 inches through the cable opening. If drilling an opening is not possible, use the cable conduits on the back side of the bracket.

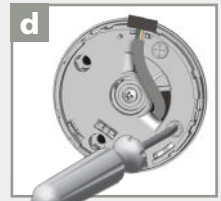

Position the bracket and secure using the 4 screws to avoid vibrations.



Open the protection cover, plug the connector, and position the cable in the slit.

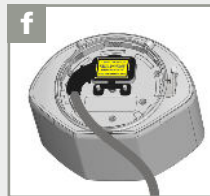

Close and secure the protection cover. **NOTE: FACTORY WARRANTY VOIDED IF PROTECTION COVER IS NOT USED!**

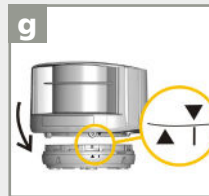

Position the housing on the bracket.

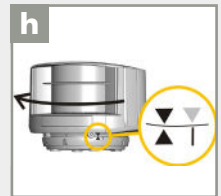

Rotate the sensor until the two triangles are face to face.

2 WIRING

Use the visual aid below to ensure correct wiring to the door control.

WIRE COLORS	FUNCTION
Red (+)	Power supply (10 – 35 VDC)
Black (-)	
White	Relay 1: Opening Field
Green	
White/Black	Relay 2: Safety Field
Green/White	
Blue (+)	Test
Blue/White (-)	
Orange	Learn
Orange/Black	

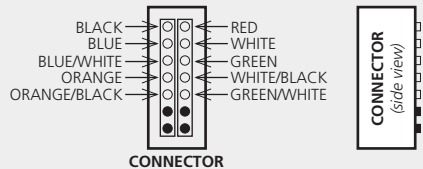

To **launch a Learn**, apply power for the length of time in which the Learn is to be performed (minimum of 1 millisecond).

⚠ No test function:
connect blue and blue/white wires to power supply (no polarity)

⚠ No Learn via input:
connect orange and orange/black wires to ground/ common

3 POSITIONING



Unlock the sensor and activate the visible laser beams.

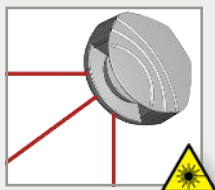

The visible laser beams indicate the approximate position of curtain C1 and the angle of the detection field.

The visible laser beams will remain active for 15 minutes or can be turned off the same way they were activated.

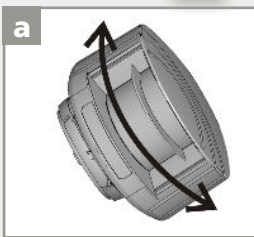

Adjust the **lateral position** of the detection field.

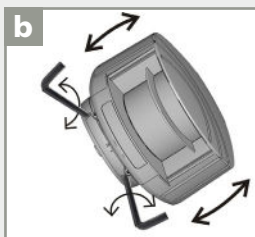

Adjust the **tilt angle** of the detection field with the 3 mm hex key.

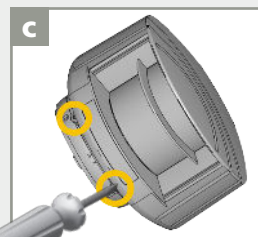

Lock the position of the mounting bracket to avoid malfunctioning in case of extreme vibrations.

4 MOUNTING SIDE

Select the corresponding mounting side.

The sensor learns its environment and automatically determines the detection field(s). Both red LEDs flash slowly and the 3 visible laser beams automatically light up for 30 seconds.

Stay outside of the detection field to avoid disturbances.



WITH BACKGROUND



The sensor memorizes the floor as reference point and signals a fault when its orientation is changed (observe orange flashing LED).

WITHOUT BACKGROUND

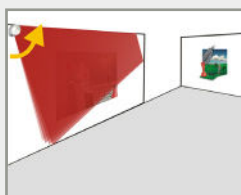

No reference point is memorized. No alarm in case of interference.

5 FIELD DIMENSIONS

FIELD 1

WIDTH  **A** 0 2 0 - 9 8 4 0 0 0
20 in - 984 in field 2 = field 1

HEIGHT  **B** 0 2 0 - 9 8 4 0 0 0
20 in - 984 in no field

400 in

400 in

FIELD 2

WIDTH  **C** 0 2 0 - 9 8 4 0 0 0
20 in - 984 in no field

HEIGHT  **D** 0 0 4 - 9 8 4
4 in - 984 in

400 in

400 in

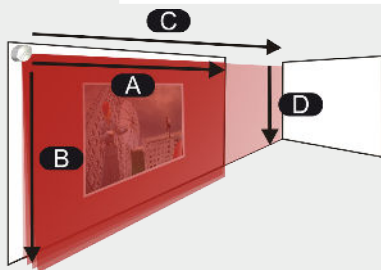

EXAMPLES

 **A** 0 6 2 for a field width of 62 in

 **B** 0 4 5 for a field height of 45 in

IMPORTANT: Test the proper operation of the installation before leaving the premises.

LEARN

The Learn can be launched either via remote control or by connecting the orange and orange/black wires.

Launch a Learn under the following conditions:

- after changing the sensor position
- when new objects are added to or changed in the detection zone

During Learn, the sensor learns its surroundings and adapts the detection zone shape. Objects in the detection field will be cut out.

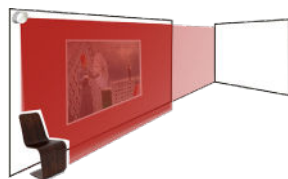

Stay outside of the detection field to avoid disturbances.

To launch a Learn via remote control, use the following sequence:

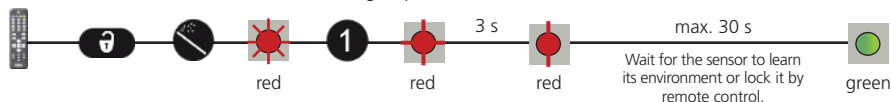

REMOTE CONTROL ADJUSTMENTS (OPTIONAL)

ACTIVE DETECTION CURTAINS

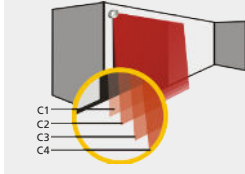

CURTAIN C1 C2 C3 C4

- 0 deactivate curtain on both fields
- 1 activate curtain only on field 1
- 2 activate curtain only on field 2
- 9 activate curtain on both fields

Ex:



C1 + C2 are active on safety field
C3 + C4 are active on optional field



C1 is active on both fields
C2+C3 are active on safety field
C4 is inactive



All curtains are active on both fields

The distances between the curtains depend on the mounting height and location. When mounted on the left, the distance between curtain C1 and curtain C4 is approximately 0.3 ft for every foot (mounting height).

Example: At 10 feet, the distance between C1 and C4 is 1.5 feet.

UNCOVERED ZONE



2	4	6	8	10	in
---	---	---	---	----	----

IMMUNITY FILTER

FOR CRITICAL ENVIRONMENTS
(e.g. RAIN, SNOW, FOG)

indoor	outdoor low	outdoor med	outdoor high
--------	-------------	-------------	--------------

FOR CRITICAL OBJECTS
(e.g. BLACK CARS)

indoor	outdoor low	outdoor med	outdoor high
--------	-------------	-------------	--------------



MIN. OBJECT SIZE

(approximate values)



off	2	4	6	8	in
-----	---	---	---	---	----

OUTPUT ACTIVATION DELAY

(approximate values)

The outputs are triggered after a constant detection time of x ms. (ex: value 3 = 300 ms)

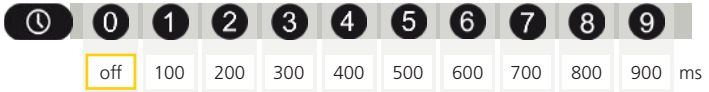

DETECTION FIELD REDIRECTION

R = relay output



R1	field 1	field 1 or field 2
R2	field 2	field 2

OUTPUT CONFIGURATION



R1 R2

R = relay output











R1	A - NO	P - NC	P - NC	A - NO
R2	P - NC	A - NO	P - NC	A - NO

A = active
P = passive

NO = normally open
NC = normally closed

TROUBLESHOOTING

	No blue LED	No power	Check cable and connection.
		Polarity of power supply is inverted	Check the polarity of the power supply.
		All LEDs have been deactivated by remote control	Activate LEDs using remote control.
	Only blue LED is on	Test input is not connected	Check wiring. The blue and blue/white cable must be connected to the test input or the power supply.
	Detection LED remains green	Detection field too small or deactivated	Check size of fields.
		Object size is too small	Launch a Learn. Decrease minimum object size.
	Detection LED remains red	Someone/Something is in the detection field	Step out of the field and/or remove the any object(s) from the field.
		Field is touching floor/wall/door – this leads to detection	Activate the 3 red beams and check if the position of the sensor is correct. If not, adjust the hex screws. Verify the field size. Launch a Learn.
	Orange LED flashing and detection LEDs are red	No background (reference point) is found	Check position of sensor. Check the mounting side setting. If no reference point is found, set the mounting side to value 3 to 5. Launch a new Learn.
		Sensor is masked	Verify and clean the front screens with a damp cloth.
	Orange LED is on Both detection LEDs are orange	Power supply voltage exceeds acceptable limits	Check power supply voltage.
		Sensor exceeds temperature limits	Verify the temperature of the environment. Protect the sensor from sunlight using a cover, if necessary.
		Internal error	Wait a few seconds. If the LED remains ON, reset the power supply. If the LED turns on again, replace the sensor.
	Sensor does not respond to the remote control	30 minutes after last use, sensor locks access to RC	Cut and restore power supply. RC is accessible again for 30 minutes.
		Remote control batteries not installed properly or are dead	Check battery orientation or replace the batteries.
		Remote control not pointed correctly	Point the remote control towards the sensor, but with a slight angle. The RC should not be pointed in a right angle in front of the sensor.
		Reflective object is close to the sensor	Avoid highly reflective material in proximity to the sensor.
	Sensor does not unlock	Access code needs entered or an incorrect code was used	Cut and restore power supply. No code is required to unlock during the first minute after powering.



Can't find your answer?
Visit www.beainc.com or scan QR code for Frequently Asked Questions!

TECHNICAL SPECIFICATIONS

Technology:	LASER scanner, Time-of-Flight measurement		
Detection mode:	motion and presence		
Detection range:	Default: 33' x 33' @ 2% remission factor (max. 82 ft x 82 ft)		
Angular resolution:	0.3516°		
Min. detected object size (typ.):	0.8 in @ 10 ft 1.4 in @ 16 ft 2.8 in @ 33 ft 6.9 in @ 82 ft		
Emission characteristics			
IR laser:	wavelength 905 nm; output power 0.10mW (CLASS 1)		
Red visible laser:	wavelength 635 nm; output power 0.95mW (CLASS 2)		
Supply voltage:	10 – 35 VDC @ sensor side		
Power consumption:	< 5 W		
Peak current @ power-on:	1.8 A (max. 80 ms @ 35 V)		
Cable length:	33'		
Response time:	typ. 20 ms (max. 80 ms) + output activation delay		
Output:	2 electronic relays (galvanic-isolated – polarity-free)		
Max. switching voltage:	35 VDC / 24 VAC		
Max. switching current:	80 mA (resistive)		
Switching time:	t _{ON} = 5 ms; t _{OFF} = 5 ms		
Output resistance:	typ 30 Ω		
Voltage drop on output:	< 0.7 V @ 20 mA		
Leakage current:	< 10 μA		
Input:	2 optocouplers (galvanic-isolated – polarity-free)		
Max. contact voltage:	30 VDC (over-voltage protected)		
Voltage threshold:	Log. Active High: > 8 VDC Log. Active Low: < 3 VDC		
Response time monitoring input:	< 5 ms		
LED signal:	1 blue LED: power-on status 1 orange LED: error status 2 bi-colored LEDs: detection/output status (green = no detection, red = detection)		
Dimensions:	3 5/8" x 2 3/4" x 5" (W x H x D) mounting bracket: + 1/2"		
Material:	PC/ASA		
Color:	Black		
Mounting angles on bracket:	-45°, 0°, 45°		
Rotation angles on bracket:	-5 – 5° (lockable)		
Tilt angles on bracket:	-3 – 3°		
Protection degree:	NEMA 4 / IP65		
Temperature range:	powered: -22 – 140 °F (-30 – 60 °C) unpowered: 14 – 140 °F (-10 – 60 °C)		
Humidity:	0 – 95% non-condensing		
Vibrations:	< 2G		
Pollution on front screen:	max. 30%, homogenous		
Norm conformity:	2006/95/EC: LVD 2004/108/EC: EMC IEC 60825-1:2007 IEC 61000-6-2:2005 2002/95/EC: RoHS IEC 60529:2001 IEC 60950-1:2005 IEC 61000-6-3:2006		

Specifications are subject to change without prior notice. All values measured in specific conditions.

BEA, INC. INSTALLATION/SERVICE COMPLIANCE EXPECTATIONS

BEA, Inc., the sensor manufacturer, cannot be held responsible for incorrect installations or incorrect adjustments of the sensor/device; therefore, BEA, Inc. does not guarantee any use of the sensor/device outside of its intended purpose.

BEA, Inc. strongly recommends that installation and service technicians be AAADM-certified for pedestrian doors, IDA-certified for doors/gates, and factory-trained for the type of door/gate system.

Installers and service personnel are responsible for executing a risk assessment following each installation/service performed, ensuring that the sensor/device system performance is compliant with local, national, and international regulations, codes, and standards.

Once installation or service work is complete, a safety inspection of the door/gate shall be performed per the door/gate manufacturer's recommendations and/or per AAADM/ANSI/DASMA guidelines (where applicable) for best industry practices. Safety inspections must be performed during each service call – examples of these safety inspections can be found on an AAADM safety information label (e.g. ANSVDASMA 102, ANSVDASMA 107, UL294, UL325, and International Building Code).

Verify that all appropriate industry signage, warning labels, and placards are in place.

