



# R2E-100 USER'S GUIDE

## ACTIVE INFRARED, REQUEST-TO-EXIT SENSOR – DUAL RELAY OUTPUT

### 1 Description



The R2E-100, including all peripheral accessories, is an active infrared, request-to-exit sensor for applications located inside the protected premise. It is UL Listed as a request-to-exit device under the UL 294 Standard and the CAN/ULC-S319 standard. The request-to-exit device is rated a “class 1” as per the CAN/ULC-S319 standard.

The R2E-100 is designed to mount on or above a door header so that its detection pattern is placed precisely in front of the door handle. In this scenario, when the user reaches for the door handle to exit, the electronic locking (EL) device is released, and the person can exit. The active infrared detection curtain of R2E-100 is well defined to keep the door secure, while rejecting parallel traffic and objects slid under the door. The detection distance, or range, of the sensor is adjustable from 20 to 48 inches.

The R2E-100 Re-lock Mode can be selected to run in timer mode or door position mode. In timer mode, the relay hold-time will control when the security device is re-locked, and it is adjustable from 0.5 to 60 seconds. In addition, the timer mode features selectable sub-modes of operation, re-starting mode (the relay hold time will not expire as long as the sensor is in detection) or non-re-starting mode (the relay will remain active for only the adjusted relay hold time). In door position mode, a door position switch connected to the door position switch input on the R2E-100 will control when the door is re-locked. The door position mode also has an advanced re-locking feature that is selectable as 10 or 30 seconds. For instance, if the sensor has gone into detection but the door has not been opened, the R2E-100 will re-lock the door and become secure again.

The R2E-100's relay output consists of two Form “C” contacts that can be wired as normally-opened or normally-closed. Also, with the R2E-100, there is no need for any additional surge protection in the wiring of the EL device to the relay, as surge protection is already built into the sensor. This built-in protection eliminates the need for any additional components.

The R2E-100 also contains an alarm that can be activated to sound when the door is open or when the EI device is released, depending upon the sensor's mode. The alarm's volume can also be adjusted or turned off.

Finally, the R2E-100 provides for 3 DRY auxiliary inputs: a push button or other request to exit device, a card reader or other request to enter device, and a door position switch.

### 2 Specifications

DESCRIPTION	SPECIFICATION
Detector Type	Active, focused Infrared
Supply Voltage	12 – 24 VAC/VDC ±10%, 60 Hz
Current Consumption	155 mA (sounder off) / 200 mA (sounder max volume)
Temperature	-20 – 120°F (-29 – 49°C) <i>For UL Listed installations, the temperature range is 32 – 120°F (0 – 49°C).</i>
Humidity	0 – 93% non-condensing for ULC-S319 installations 0 – 85% non-condensing for UL-294 Listed installations
Detection Distance (Range)	Potentiometer adjusted from 20 – 48”
Relay	Two Form “C” contact sets rated for 1.3A @ 24 VAC / 1.3A @ 30 VDC 0.6pf (Power Factor)
Relay Hold Time	Potentiometer adjusted from 0.5 – 60 seconds
Sounder	85 dB max with adjustable volume
Indicator LEDs	Green, red, yellow, orange
REX Input	DRY Contact, normally-opened (NO)
Card Reader Input	DRY Contact, normally-closed (NC) – Can be disabled/enabled via DIP
Door Position Switch Input	DRY Contact, normally-opened (NO) – Can be disabled/enabled via DIP
Dimensions	6 7/10” (W) x 2” (H) x 1 7/10” (D) (174.63 mm x 51 mm x 47.63mm)
Material	Plastic (ABS and PC)
Housing Color	Black
Wiring Interface	JST (14-pin), 4’ cable
Certifications	UL/ULC 294/S319, FCC Part B

## 3 Component ID

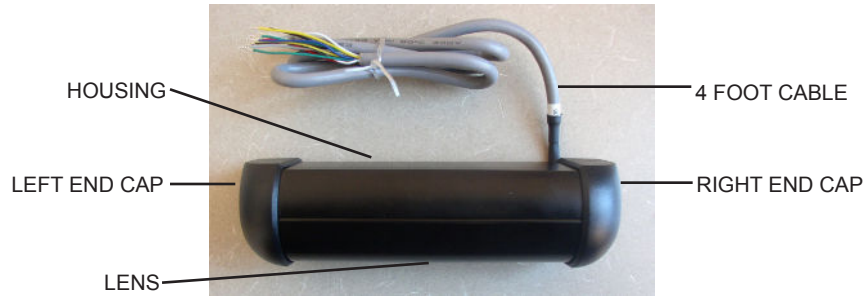

## 4 Precautions



- Shut off all power going to header before attempting any wiring procedures.
- Maintain a clean and safe environment when working in public areas.
- Constantly be aware of pedestrian traffic around the door area.
- Always stop pedestrian traffic through the doorway when performing tests that may result in unexpected reactions by the door.
- ESD (electrostatic discharge): Circuit boards are vulnerable to damage by electrostatic discharge. Before handling any board, ensure you dissipate your body's ESD charge.
- Always check placement of all wiring before powering up to ensure that moving door parts will not catch any wires and cause damage to equipment.
- Ensure compliance with all applicable safety standards (i.e. ANSI A156.10) upon completion of installation.
- DO NOT attempt any internal repair of the components. All repairs and/or component replacements must be performed by BEA, Inc. Unauthorized disassembly or repair:
  1. May jeopardize personal safety and may expose one to the risk of electrical shock.
  2. May adversely affect the safe and reliable performance of the product resulting in a voided warranty.

## 5 Pre-Installation Check

1. When preparing to wire multiple devices together for a system configuration, it is best to ensure the correct operation of each device independently before starting, to help reduce troubleshooting time later in the event of a discrepancy.
2. Prior to installing any equipment, ensure correct line voltage and stability. When applying equipment on a new installation which utilizes new electrical supply circuits, always ensure that correct line voltage exists and is stable. Remember to shut off the power after this is checked and before performing any wiring to the system.

## 6 Mechanical Installation

*NOTE: The R2E-100 and any connected devices must be mounted inside the protected area to be compliant with UL294/ULC-S319.*

To prepare the R2E-100 for mounting to the header, perform the following:

1. Remove only the right end cap from the R2E-100 (Picture 1). It is attached by one Phillips head screw.
2. Remove the lens from R2E-100 by simply sliding it out at the right end of the housing approximately a 1/4 inch and then gently pull the lens down and away from the housing (Picture 2).



3. Slide the PCB (printed circuit board) and plastic clips out of the housing and set them aside (Picture 3).



## 6 Mechanical Installation (cont.)

With the R2E-100 disassembled, begin the installation procedure.

1. Hold the R2E-100 up to the pre-determined location, which should be centered directly above the door handle (Picture 4 and Picture 5) and attach using the 2 self-drilling screws that are included with the package. *The housing has pre-drilled mounting holes at each end (Picture 6).* It may be necessary to drill a pilot hole (1/8" diameter) in the header for ease of screw installation. Ensure the R2E-100 is mounted securely at each end.

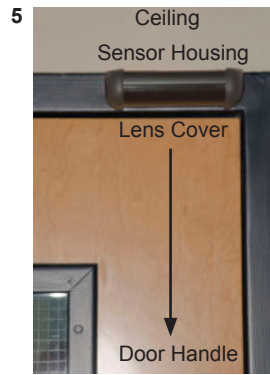
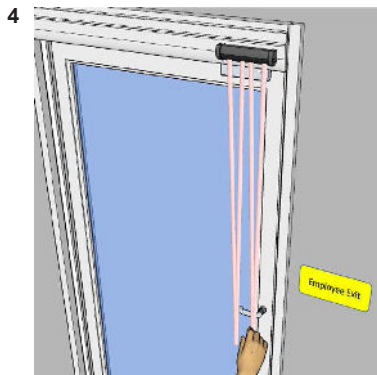

Pre-drilled Mounting Holes  
approx. 4 1/4" apart

Install R2E-100 with Lens Cover Facing Down Toward Door Handle

2. If the R2E-100 is mounted directly to door header and cabling is to pass directly into header, drill a 3/8" hole next to the sensor's right end cap to allow wire passage into header. The wire passage hole should be in a location that aligns with the cut-out in the housing.

## 7 Electrical Installation

Once the R2E-100 is attached to header, cabling, and wiring may be completed. Use the cable that is provided with a 14-pin connector.

For UL Listed installations, the R2E-100 should only be powered by a UL 294 Listed, power limited power supply, as well as connected to a UL Listed electronic locking (EL) device or associated access control hardware.

For CAN/ULC-S319 Listed installations, the R2E-100 should only be powered by a ULC-S319 or ULC-S318 Listed, power limited or Class 2 power supply, as well as connected to a ULC-S319 Listed electronic locking (EL) device, card reader/keypad, and Door/REX switches.

Terminals and leads comply with CSA C22.1, Canadian Electrical Code, Part 1, Safety Standard for Electrical Installations.

14-PIN CONNECTOR WIRE COLOR	SIGNAL
Red	12 to 24 VAC / DC +/- 10%
Black	12 to 24 VAC / DC +/- 10%
White/Black Stripe	Relay 1 Common
Green/Black Stripe	Relay 1 Normally Open
Yellow/Black Stripe	Relay 1 Normally Closed
White	Relay 2 Common
Green	Relay 2 Normally Open
Yellow	Relay 2 Normally Closed
Blue	DRY Card Reader Input
Blue/White Stripe	DRY Card Reader Input
Orange	DRY REX Input
Orange/White Stripe	DRY REX Input
Brown	DRY Door Position Switch Input
Brown/White Stripe	DRY Door Position Switch Input

**NOTE:** ALL CIRCUITS ARE POWER LIMITED, CLASS 2.

## 7 Electrical Installation (cont.)

### UL/ULC SPECIFIC NOTES:

For UL 294 Listed installations, the R2E-100 should only be powered by a UL 294 Listed, power limited power supply, as well as connected to a UL Listed electronic locking (EL) device and associated access control hardware.

For CAN/ULC-S319 Listed installations, the R2E-100 should only be powered by a ULC-S319 or ULC-S318 Listed, power limited or Class 2 power supply or Canadian Class 2 transformer, as well as connected to the following ULC-S319 Listed devices such as a Control Panel, an electronic locking (EL) device, a card reader/keypad, and the Door/REX/ Momentary switches.

*BEA carries two UL listed power supply products:*

- BEA PN 10PS12-24 – 12VDC or 24VDC @ 1.75A (Altronix AL175UL – UL 294 listed Power Supply Unit 39BA – CUL listed CSA Standard C22.2 No. 205-M1983 – File# BP5864)
- BEA PN 10PS12-24D – 12VDC or 24VDC @ 1.75A with battery backup (Altronix AL175ULX – UL 294 listed Power Supply Unit 39BA – CUL listed CSA Standard C22.2 No. 205-M1983 – File# BP6714)

*BEA carries several UL listed maglock products:*

- BEA PN 10MAGLOCK1UL – single 1200lb electromagnetic lock (UL and CUL listed – File# S24600)
- BEA PN 10MAGLOCK3UL – single 600lb electromagnetic lock (UL and CUL listed – File# S24600)
- BEA PN 10MAGLOCK5UL – double 1200lb electromagnetic lock (UL and CUL listed – File# S24600)
- BEA PN 10MAGLOCK6UL – double 600lb electromagnetic lock (UL and CUL listed – File# S24600)

An example of the UL294 control panel, card reader, REX and Door switches:

- GE ACU2, ACU2X, ACUXL Controller (UL-294 listed – File# BP5721)
- HID Card Reader Model 83120B (UL-294 listed – File# BP6568)
- Securitron Request to Exit Switch PN EEB2 (UL-294 listed - File# BP7041)
- GE Door Position Switch PN 1125W-N (UL listed)

The three inputs to the R2E must be used as a “Dry Input” with no voltage applied from the Card Reader, REX, or DPS.

The use of any add-on, expansion, memory or other module manufactured or supplied by the manufacturer or manufacturer’s representative will invalidate the CAN/ULC-S319 certification.

For UL 294 and NFPA 101 sections 7.2.1.6.2.1 wire the lock for fail safe condition for the loss of power.

The audible sounder on the device is not intended as a burglary alarm.

The maximum detection range is 4 feet.

CAN/ULC-S319 limits the rated output of the audible signal device (stated as a Sound Pressure Level (SPL) from 70 dBA to a maximum of 100 dBA at 1 meter.

UL-294 limits the rated output of the audible signal device to a minimum of 85 dBA at 10 feet.

When used with electric strikes on supervised portals, request-to-exit devices shall by-pass portal alerts caused by exiting. When used with electromagnetic locks on supervised portals, request-to-exit devices shall signal the access control unit to release the electromagnetic locks as well as to by-pass portal alerts caused by exiting.

For UL 294 / Canadian ULC-S318: Electronic Security Device Inc. PN: SPS-3.3, 24VDC – 3A - Supervised Power Supply/Charger module, Universal Input: 85vac–260vac, ULC File Number UTRZ8.S8102 (UL-294 listed - File# BP9019)

For Canadian Class 2: Signal Transformer Company PN: CL2-25-24, Dual primaries, 115/230 V, 50/60 Hz, Secondary: 24V @ 1.05A, Secondary Fuse Required 1.5A Non-inherently limited, ULC File Number: XOKV8:E116583

### UL294 PERFORMANCE RATINGS:

Access Control Line Security:	Level I
Destructive Attack:	Level I
Endurance:	Level IV
Standby Power:	Level I

## 8 Mechanical Adjustment

**NOTE:** See Appendix 3 for Installation Tips.

Once all installation, wiring, and cabling procedures have been completed, mechanical adjustments of the sensor field can be made. Please note that further adjustments may be required after powering and walk-testing the detection field.

Aside from placement on the header, the only mechanical adjustment remaining is the sensor's angle adjustment. The R2E-100 is factory pre-set to the 5° position, but may be reduced to a 0° position or increased to a 10° position. The greater the angle, the farther from the door handle the pattern will be. The 0° angle should only be used when the R2E-100 is mounted to a BodyMount block or to a door soffit that extends out past the face of the door handle. In this case, the 0° setting would improve the location of the detection field across the threshold area of the door handle. For most applications, it is recommended that the unit be powered and both hand- and walk-tested at the factory pre-set 5° angle. After testing, if the detection field needs to be changed, proceed with other angle setting as shown below. If the sensor is detecting erratically, there is a good possibility that the IR beams are reflecting off of the door handle and the sensor should be adjusted outward.

1. To change the angle setting, both the end cap and lens must be removed (as shown in Section 6). The 14-pin connector may also be removed if it has been wired. Grasp the bottom of each plastic clip and gently pull the clips forward and downward. Remove the clips and PCB from the housing.
2. Once the PCB is completely removed from the housing, the sensor's detection angle may be changed. There are two clips per R2E-100 and the angle and plastic notch, must match for each clip. The positions are shown below.

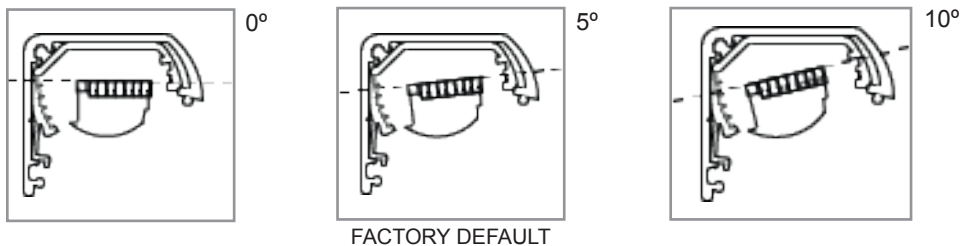

3. Snap the PCB back into the housing, snap the lens back into place, and proceed with power-up procedures. Leave the right end cap off until all final sensor adjustments have been made (as described in Section 9). Once the sensor has been walk-tested and adjusted correctly, re-install the right end cap.

## 9 Sensor Adjustment

Once the sensor is completely wired and powered, you can now adjust the sensor.

1. The detection distance (range) threshold is adjusted using the **single-turn** 'RNG' potentiometer (Picture 9). To decrease the detection distance, turn the potentiometer counterclockwise. The minimum detection distance is approximately 20". To increase the detection distance, turn the potentiometer clockwise. The maximum detection distance is approximately 48".

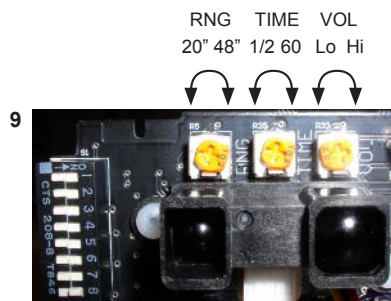

2. The relay hold time is adjusted using the **single-turn** 'TIME' potentiometer (Picture 9). Adjustment is from 1/2 to 60 sec. The potentiometer will be non-linear, with the first 10 seconds covered by the first half potentiometer sweep and the 11 to 60 seconds covered by the second half potentiometer sweep. To decrease the hold time, turn the potentiometer counterclockwise. To increase the hold time, turn the potentiometer clockwise.
3. The alarm volume is adjusted using the **single-turn** 'VOL' potentiometer (Picture 9). To decrease the volume, turn the potentiometer counterclockwise. To increase the volume, turn the potentiometer clockwise. The rated output of an audible signal device, stated as a sound pressure level (SPL), shall produce a minimum of 70 dBA up to a maximum of 100 dBA at 1 m, when driven at the rated input. For CAN/ULC installations this is achieved by turning the VOL potentiometer to the maximum setting.

## 9 Sensor Adjustment (cont.)

### 4. DIP Switch Settings 8 position DIP (Picture 9).

DIP 1: R2E-100 will enter either fail-safe (ON) or fail-secure (OFF) if stuck in constant detection (masked).

DIP 2: Re-lock mode is door position mode (ON) or timer mode (OFF). \*

DIP 3: Door position mode advanced re-lock time is 10 seconds (ON) or 30 seconds (OFF). \*

DIP 4: Relay hold-time restart (ON) or continue counting down (OFF) upon re-detection.

DIP 5: Alarm enabled (ON) or disabled (OFF).

DIP 6: Enable the Card Reader Input (ON) or disable the Card Reader Input (OFF). Card Reader Input is normally-closed (NC).

DIP 7: Alarm sounds when normally-closed (NC) Card Reader Input is opened (ON) or alarm does not sound based on Card Reader Input (OFF).

DIP 8: Future development.

\* A normally-closed door position switch (switch is closed when door is closed) is required to be connected to the Door Position Switch Input if this feature is ON. The door position switch is not included.

- a) DIP 1: When any of the enabled inputs are in constant detection for greater than 10 seconds successively, the sensor is considered masked and will enter either a fail-safe mode (ON) where the door is unlocked or a fail-secure mode (OFF) where the door is locked. As soon as the sensor is no longer in detection, it will resume normal operation.
- b) DIP 2: Re-lock mode is door position mode (ON), and re-locking will be based on a door position switch which will re-lock the door after the door has first been opened and then re-closed. Re-lock mode is timer mode (OFF), and re-locking will be based solely on the potentiometer adjusted relay hold time. A normally-closed door position switch (switch is closed when door is closed) is required to be connected to the Door Position Switch Input if this feature is ON. The door position switch is not included.
- c) DIP 3: If Re-lock mode is door position mode as selected by DIP 2 and any of the enabled inputs go into detection but the door does not open, the door re-locks after 10 seconds (ON) or 30 seconds (OFF) and becomes secure again. A normally-closed door position switch (switch is closed when door is closed) is required to be connected to the Door Position Switch Input if this feature is ON. The door position switch is not included.
- d) DIP 4: If Re-lock mode is timer mode as selected by DIP 2 and any of the enabled inputs go into detection and the detection is held or repeated, the potentiometer adjusted relay hold time will be restarting (ON), where the relay hold time will not expire as long as the sensor is in detection. Timer mode will be non-restarting (OFF), where the relay will remain active for **only** the adjusted relay hold time.
- e) DIP 5: Enable the alarm (ON) or disable the alarm (OFF). If the alarm is enabled and the Re-lock mode is in door position mode, the alarm will only sound whenever the door is opened (door position switch input is opened). If the Re-lock mode is in timer mode, the alarm will sound as long as the relay hold time has not expired.
- f) DIP 6: Enable the Card Reader Input to provide activation (ON). Disable the Card Reader Input from providing an activation. The Card Reader Input is normally-closed (NC).
- g) DIP 7: If the Card Reader Input is enabled on DIP 7 and the alarm is enabled on DIP 5, enable the alarm to sound (ON) when Card Reader Input is opened under normal operation or tampered with by wire cutting from the reader and leaving the input opened. The alarm will not sound based on the Card Reader Input (OFF).
- h) DIP 8: Currently has no function, but is allotted for future development.

## 10 Indicator LEDs

Green = On/Running and no detection

Red = Object in detection or input activated (example: hand in detection, or REX asserted)

Yellow = Relay active by relay hold time (re-lock mode set to timer mode as selected by DIP 2)

Flashing Orange = When the sensor or any of the enabled inputs are in constant detection for greater than 10 seconds successively. As soon as the sensor is no longer in detection, it will resume normal operation.



## 11 Complete Installation

Before completing the installation you should test the sensor. If needed, adjust the sensor as necessary.

1. Test that the sensor releases the security device when activated.
2. Test the activation height of the sensor.
3. Test the activation zone parallel to the door and in front of the door handle.

When completely finished with adjustments, reinstall the lens and the right end cap.

## 12 Troubleshooting

PROBLEM	PROBABLE CAUSE	CORRECTIVE ACTION
R2E-100 is detecting erratically	Sensor's IR beams are reflecting off the door handle	Adjust the sensor so that the beams are in front of the handle.
Bosch sensor is being replaced on an existing installation by a R2E-100		See BEA Application Note.



Can't find your answer? Visit [www.BEAsensors.com](http://www.BEAsensors.com) or scan QR code for Frequently Asked Questions!

This device complies with Part 15 of the FCC Rules. Operation is subject to the following two conditions: (1) This device may not cause harmful interference, and (2) this device must accept any interference received, including interference that may cause undesired operation. Changes or modifications not expressly approved by BEA Inc. could void the user's authority to use this equipment.

Patent Pending

### BEA, INC. INSTALLATION/SERVICE COMPLIANCE EXPECTATIONS

BEA Inc., the sensor manufacturer, cannot be held responsible for incorrect installations or incorrect adjustments of the sensor/device; therefore, BEA Inc. does not guarantee any use of the sensor/device outside its intended purpose.

BEA Inc. strongly recommends that installation and service technicians be AAADM-certified for pedestrian doors, IDA-certified for doors/gates, and factory-trained for the type of door/gate system.

Installers and service personnel are responsible for executing a risk assessment following each installation/service performed, ensuring that the sensor/device system performance is compliant with local, national, and international regulations, codes, and standards.

Once installation or service work is complete, a safety inspection of the system shall be performed and documented per the manufacturer's recommendations or industry guidelines. Examples of compliance may apply to ANSI 156.10, ANSI 156.19, ANSI/DASMA 102, ANSI/DASMA 107, UL294, UL325, and International Building Code.



A Halma company

Tech Support & Customer Service: 1-800-523-2462 | General Tech Questions: [techservices-us@BEAsensors.com](mailto:techservices-us@BEAsensors.com) | Tech Docs: [www.BEAsensors.com](http://www.BEAsensors.com)

# APPENDIX 1

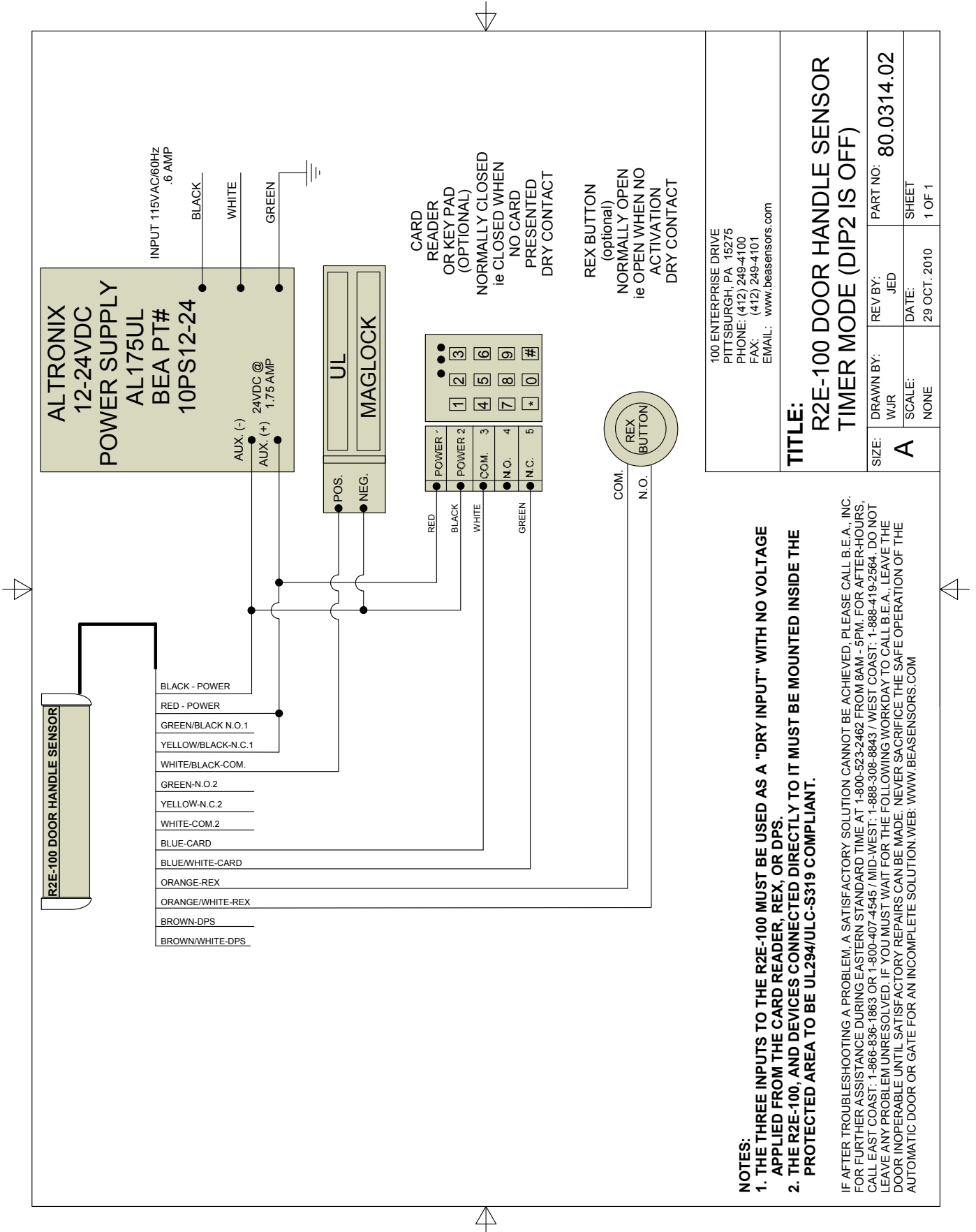



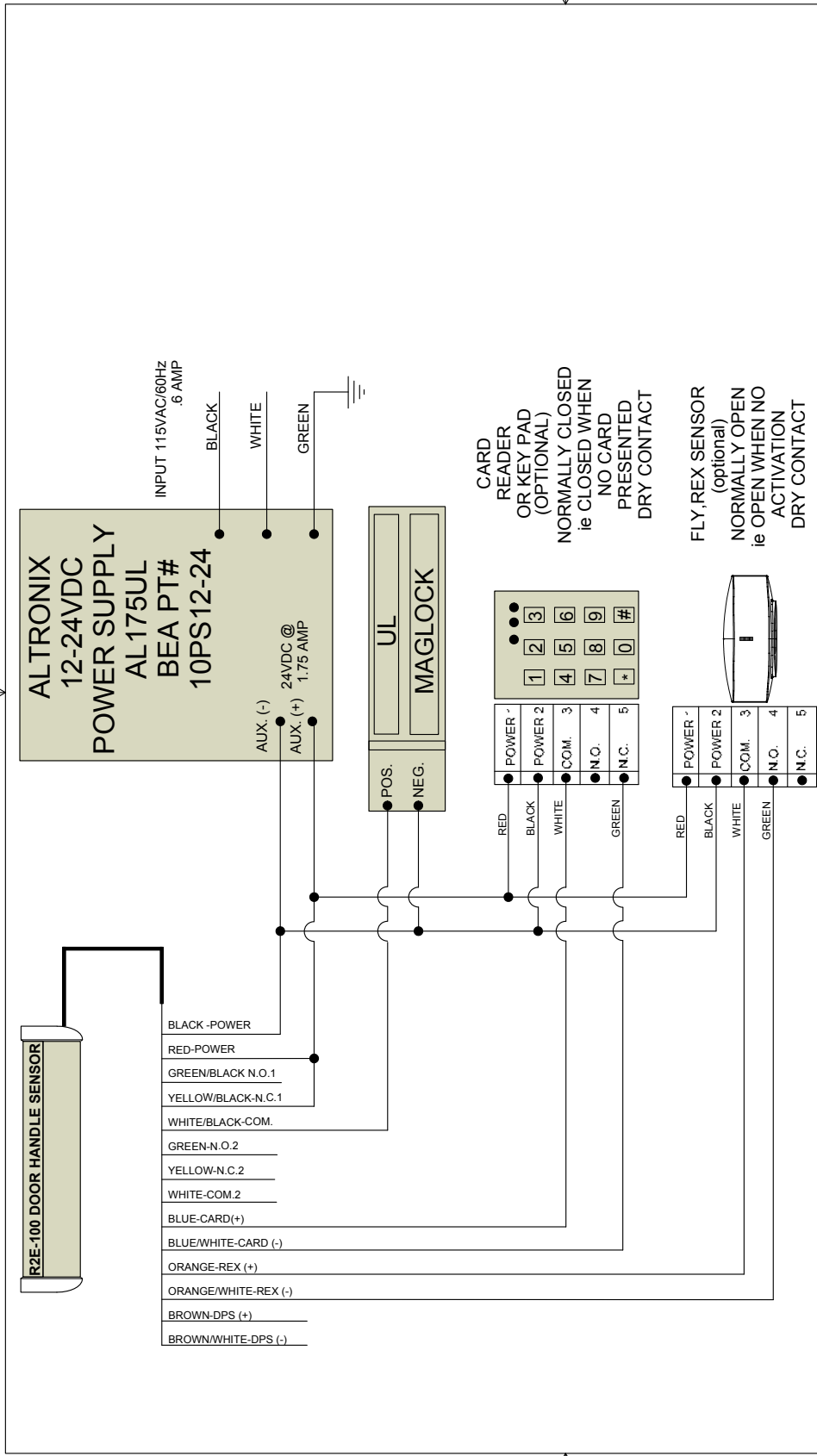

**NOTES:**  
 1. THE THREE INPUTS TO THE R2E-100 MUST BE USED AS A "DRY INPUT" WITH NO VOLTAGE APPLIED FROM THE CARD READER, REX, OR DPS.  
 2. THE R2E-100, AND DEVICES CONNECTED DIRECTLY TO IT MUST BE MOUNTED INSIDE THE PROTECTED AREA TO BE UL294/ULC-S319 COMPLIANT.

IF AFTER TROUBLESHOOTING A PROBLEM, A SATISFACTORY SOLUTION CANNOT BE ACHIEVED, PLEASE CALL B.E.A., INC. FOR FURTHER ASSISTANCE DURING EASTERN STANDARD TIME AT 1-800-523-2462 FROM 8AM - 5PM. FOR AFTER-HOURS, CALL EAST COAST: 1-866-836-1863 OR 1-800-407-4545 / MID-WEST: 1-888-308-8843 / WEST COAST: 1-888-419-2564. DO NOT LEAVE ANY PROBLEM UNRESOLVED. IF YOU MUST WAIT FOR THE FOLLOWING WORKDAY TO CALL B.E.A. LEAVE THE DOOR INOPERABLE UNTIL SATISFACTORY REPAIRS CAN BE MADE. NEVER SACRIFICE THE SAFE OPERATION OF THE AUTOMATIC DOOR OR GATE FOR AN INCOMPLETE SOLUTION.WEB: WWW.BEASENSORS.COM

100 ENTERPRISE DRIVE  
 PITTSBURGH, PA 15275  
 PHONE: (412) 249-4100  
 FAX: (412) 249-4101  
 EMAIL: www.beasensors.com

**TITLE:**  
**R2E-100 DOOR HANDLE SENSOR  
 TIMER MODE (DIP2 IS OFF)**

SIZE: <b>A</b>	DRAWN BY: WJR	REV BY: JED	PART NO: <b>80.0315.02</b>
SCALE: NONE	DATE: 13 Jan. 2012		SHEET 1 OF 1

## APPENDIX 3

### Installation Tips

The R2E-100 active infrared pattern is made up of two narrow, side-by-side detection zones that project at slightly offset angles. See Figure 1 for an illustration of the two detection zones in a typical installation. Figure 2 shows the relative position of the two zones or “spots” at a distance of 48” below the sensor (as viewed from the floor).

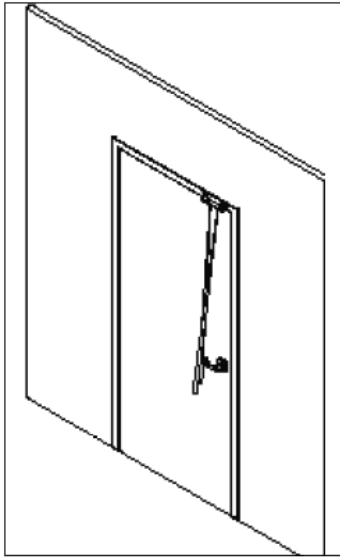

Figure 1

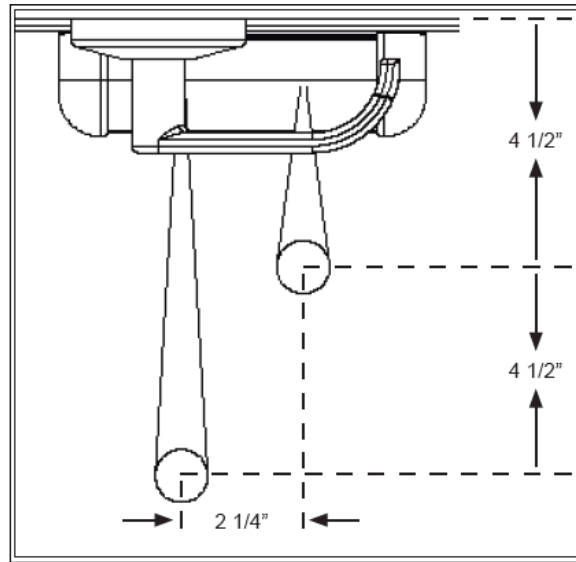

Figure 2

For best performance, adjust the position of the circuit board assembly inside the mechanical enclosure so that both zones project slightly in front of the door handle (see Figure 3). Refer to Section 8 of the User’s Guide for detailed instructions about changing the angle of the circuit board assembly.

Mount the mechanical enclosure to the wall or door header above the door so that both detection zones are located in the desired left-right position relative to the door handle (see Figure 4). Ideally the detection zones will cover the full width of the door handle (left-right) to eliminate any “holes” along the door handle.

**NOTE: DO NOT DRILL A HOLE IN THE DOOR HEADER FOR THE HARNESS OR INSTALL ENCLOSURE SCREWS UNTIL THE DESIRED LEFT-RIGHT POSITION OF THE SENSOR HAS BEEN TESTED AND CONFIRMED.**

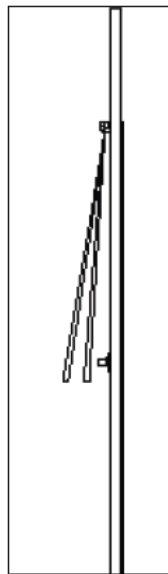

Figure 3

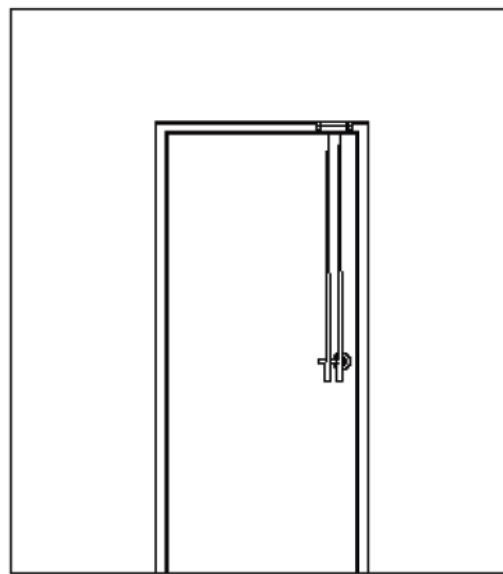

Figure 4

### TROUBLESHOOTING

If the sensor goes into activation upon power-up, it is most likely the result of one of two parameters requiring further adjustment. First, check the angle setting of the circuit board assembly in the clips (refer to Section 8 of the User’s Guide). If the sensor is angled too closely to the face of the door, the door handle will likely intersect the detection zone, thus causing a false detection. Next, turn down the RNG potentiometer (counterclockwise), which will decrease the depth of the detection zone. In applications where there is a highly reflective background (e.g. smooth tile or concrete floor), the RNG potentiometer can also be used as a sensitivity adjustment.