

NOTES:

1. 1/2 ϕ MOUNTING HARDWARE IS RECOMMENDED, STUD-ANCHOR-500 OR L-BOLT-500.
2. COATED IN 2-4 MILS ANODIZED ALUMINUM COLOR POWDER COATING.
3. *ANODIZED COATING NOT AVAILABLE.



PEDESTALPRO.COM
1-800-660-3072

UNLESS OTHERWISE SPECIFIED:

DIMENSIONS ARE IN INCHES
TOLERANCES:
FRACTIONAL $\pm 1/32$
ANGULAR: $\pm 2^\circ$
TWO PLACE DECIMAL ± 0.010
THREE PLACE DECIMAL ± 0.005

INTERPRET GEOMETRIC
TOLERANCING PER:
ASME Y14.5 -2009

NAME	DATE
DRAWN	
CHECKED	

PROPRIETARY AND CONFIDENTIAL
THE INFORMATION CONTAINED IN THIS DRAWING IS THE SOLE PROPERTY OF PEDESTALPRO LLC. ANY REPRODUCTION IN PART OR AS A WHOLE WITHOUT THE WRITTEN PERMISSION OF PEDESTALPRO LLC IS PROHIBITED.

TITLE:
INSTALLATION

Friday, May 29, 2020
9:11:32 AM

WEIGHT: 14.942

SIZE	PART NO.	REV
A	66TOW-PRO-001-ALU	0
NO SCALE		SHEET 1 OF 7

ITEM NO.	PART NUMBER	DESCRIPTION	QTY.
1	66TOW-PRO-001-ALU TUBE	6061 ALUM BODY	1
2	PLACAP-6-6-ALU	6 X 6 ALUM CAP PLATE	1
3	PLTACC-510	6" STND 304SS ACCESS PANEL	1
4	PLTBAS-6-6-ALU	6" STND ALUM BASE PLATE	1
5	--	8-32 PAN HEAD SCREW	4

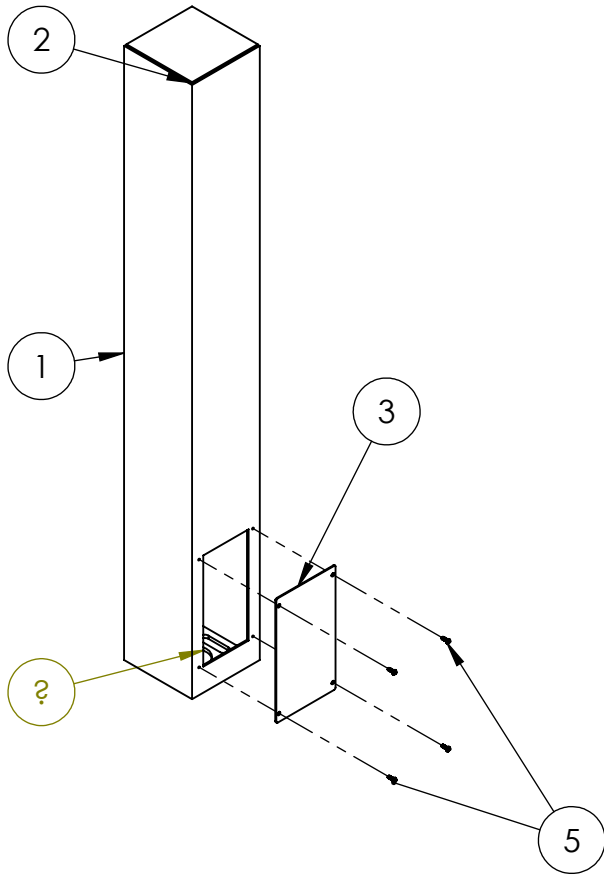

NOTES:

1. SEE STANDARD PREPARATION AND COATING INSTRUCTIONS FOR COATING PROCEDURE AND COLOR.
2. SEE STANDARD PACKAGING INSTRUCTIONS FOR PACKAGING PROCEDURE.



PEDESTALPRO.COM
1-800-660-3072

UNLESS OTHERWISE SPECIFIED:

DIMENSIONS ARE IN INCHES
TOLERANCES:
FRACTIONAL $\pm 1/32$
ANGULAR: $\pm 2^\circ$
TWO PLACE DECIMAL ± 0.010
THREE PLACE DECIMAL ± 0.005

INTERPRET GEOMETRIC
TOLERANCING PER:
ASME Y14.5 -2009

NAME DATE

DRAWN

CHECKED

PROPRIETARY AND CONFIDENTIAL

THE INFORMATION CONTAINED IN THIS
DRAWING IS THE SOLE PROPERTY OF
PEDESTALPRO LLC. ANY REPRODUCTION
IN PART OR AS A WHOLE WITHOUT THE
WRITTEN PERMISSION OF PEDESTALPRO LLC
IS PROHIBITED.

TITLE:

ASSEMBLY

Friday, May 29, 2020
9:11:32 AM

WEIGHT: 14.942

SIZE
A

PART NO.
66TOW-PRO-001-ALU

REV
0

NO SCALE

SHEET 2 OF 7