

SECTION A-A

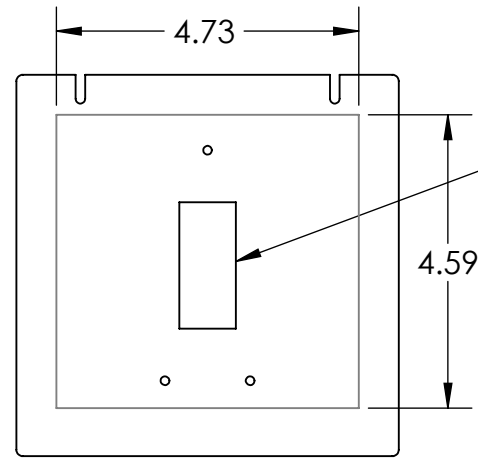

AVAILABLE CUTOUT AREA

PAXTON 010-296-US

NOTES:

1. MATERIAL OF CONSTRUCTION IS MILD STEEL.
2. 2-4 MILS BLACK WRINKLE POWDER COAT.

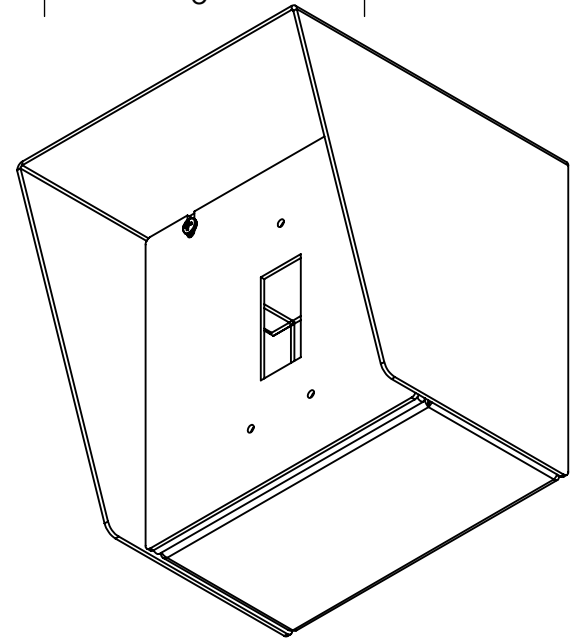

PEDESTALPRO.COM
1-800-660-3072

UNLESS OTHERWISE SPECIFIED:

DIMENSIONS ARE IN INCHES
TOLERANCES:
FRACTIONAL $\pm 1/32$
ANGULAR: $\pm 2^\circ$
TWO PLACE DECIMAL ± 0.010
THREE PLACE DECIMAL ± 0.005

INTERPRET GEOMETRIC
TOLERANCING PER:
ASME Y14.5 -2009

UNLESS OTHERWISE SPECIFIED:	NAME	DATE
DRAWN		
CHECKED		

PROPRIETARY AND CONFIDENTIAL
THE INFORMATION CONTAINED IN THIS DRAWING IS THE SOLE PROPERTY OF PEDESTALPRO LLC. ANY REPRODUCTION IN PART OR AS A WHOLE WITHOUT THE WRITTEN PERMISSION OF PEDESTALPRO LLC IS PROHIBITED.

TITLE:
INSTALLATION

Friday, May 19, 2023
9:03:17 AM

WEIGHT: 5.312

SIZE	PART NO.	REV
A	66HOU-PAXT-03-CRS	C
NO SCALE		SHEET 1 OF 6

ITEM NO.	PART NUMBER	DESCRIPTION	QTY.
1	66HOU-PAXT-03-CRS ENCLOSURE	ENCLOSURE WELDMENT	1
2	66HOU-PAXT-03-CRS DOOR	DOOR WELDMENT	1
3	HINGE	PIANO HINGE	1
4	GASKET SIDE	3/8" X .150 WEATHERSTRIPPING	2
5	GASKET TOP	3/8" X .150 WEATHERSTRIPPING	1
6	--	6-32 PAN HEAD SCREW	4
7	--	6-32 EXTERNAL TOOTH LOCK NUT	2

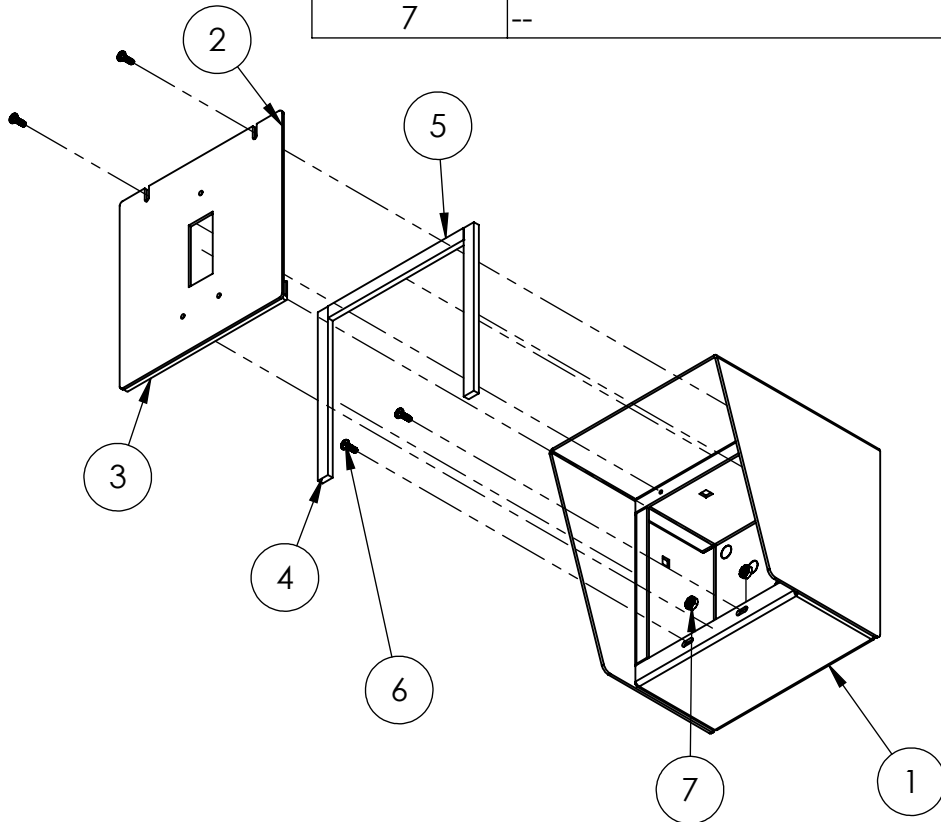

NOTES:

1. SEE STANDARD PREPARATION AND COATING INSTRUCTIONS FOR COATING PROCEDURE AND COLOR.
2. SEE STANDARD PACKAGING INSTRUCTIONS FOR PACKAGING PROCEDURE.



PEDESTALPRO.COM
1-800-660-3072

UNLESS OTHERWISE SPECIFIED:

DIMENSIONS ARE IN INCHES
TOLERANCES:
FRACTIONAL $\pm 1/32$
ANGULAR: $\pm 2^\circ$
TWO PLACE DECIMAL ± 0.010
THREE PLACE DECIMAL ± 0.005

INTERPRET GEOMETRIC
TOLERANCING PER:
ASME Y14.5 -2009

NAME DATE

DRAWN

CHECKED

PROPRIETARY AND CONFIDENTIAL

THE INFORMATION CONTAINED IN THIS
DRAWING IS THE SOLE PROPERTY OF
PEDESTALPRO LLC. ANY REPRODUCTION
IN PART OR AS A WHOLE WITHOUT THE
WRITTEN PERMISSION OF PEDESTALPRO LLC
IS PROHIBITED.

TITLE:

ASSEMBLY

Tuesday, September
11, 2018 9:34:19 AM

WEIGHT: 5.312

SIZE
A

PART NO.
66HOU-PAXT-03-CRS

REV
C

NO SCALE

SHEET 2 OF 6