

(2X)DRILL# 36
TAP 6-32

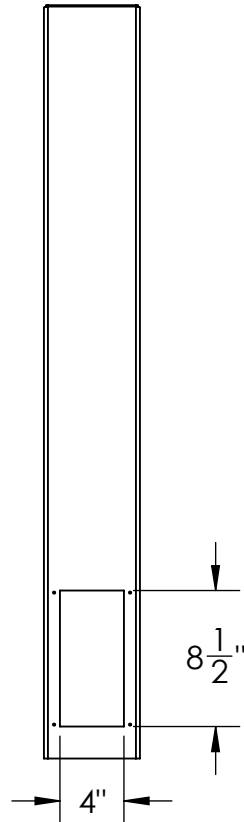

VIKING CUTOUT FITS:
PRX-3

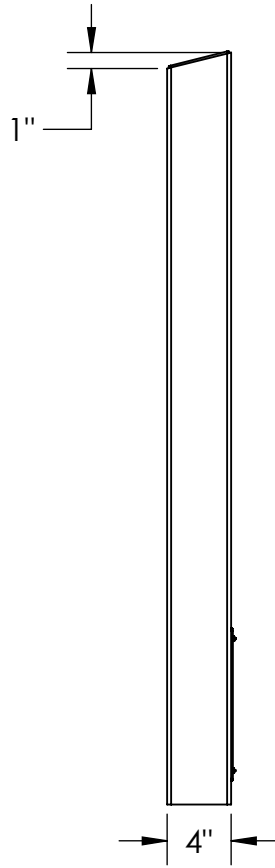
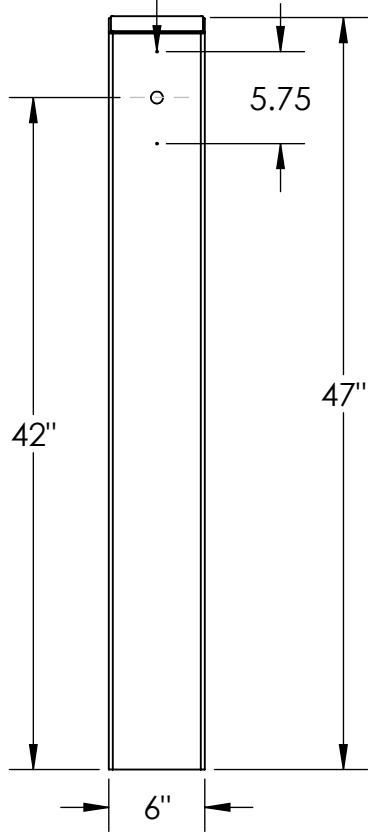
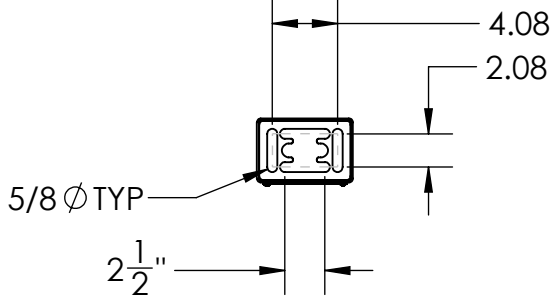
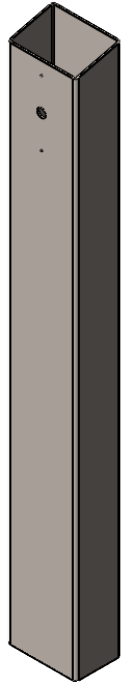

NOTES:

1. 1/2" ϕ MOUNTING HARDWARE IS RECOMMENDED FOR 5X5 BASEPLATE AND STAINLESS TOWER MODELS. L-BOLT-500, STUD-ANCHOR-500.
2. 5/8" ϕ MOUNTING HARDWARE IS RECOMMENDED FOR 8X8 BASEPLATE, 12X12 BASEPLATE, AND BOLLARD STYLE BASEPLATE MODELS. L-BOLT-625, STUD-ANCHOR-625.
3. MATERIAL OF CONSTRUCTION IS 304SS BRUSHED #4 FINISH.



PEDESTALPRO.COM
1-800-660-3072

UNLESS OTHERWISE SPECIFIED:

DIMENSIONS ARE IN INCHES
TOLERANCES:
FRACTIONAL: $\pm 1/32$
ANGULAR: $\pm 2^\circ$
TWO PLACE DECIMAL ± 0.010
THREE PLACE DECIMAL ± 0.005

INTERPRET GEOMETRIC
TOLERANCING PER:
ASME Y14.5-2009

| NAME | DATE |
|---------|------|
| DRAWN | |
| CHECKED | |

PROPRIETARY AND CONFIDENTIAL
THE INFORMATION CONTAINED IN THIS DRAWING IS THE SOLE PROPERTY OF PEDESTALPRO LLC. ANY REPRODUCTION IN PART OR AS A WHOLE WITHOUT THE WRITTEN PERMISSION OF PEDESTALPRO LLC IS PROHIBITED.

TITLE:
INSTALLATION

Tuesday, October 23,
2018 1:52:42 PM

WEIGHT:

| SIZE | PART NO. | REV |
|----------|-------------------|--------------|
| A | 64TOW-VIKI-06-304 | B |
| NO SCALE | | SHEET 1 OF 7 |

| ITEM NO. | PART NUMBER | DESCRIPTION | QTY. |
|----------|------------------------|------------------------------|------|
| 1 | 64TOW-VIKI-06-304 TUBE | TOWER WELDMENT | 1 |
| 2 | PLTACC-510 | STND 5.25 X 8.5 ACCESS COVER | 1 |
| 5 | -- | 8-32 SS HEX FLAT HEAD SCREW | 4 |
| 3 | -- | 8-32 SS BUTTON HEAD SCREW | 4 |

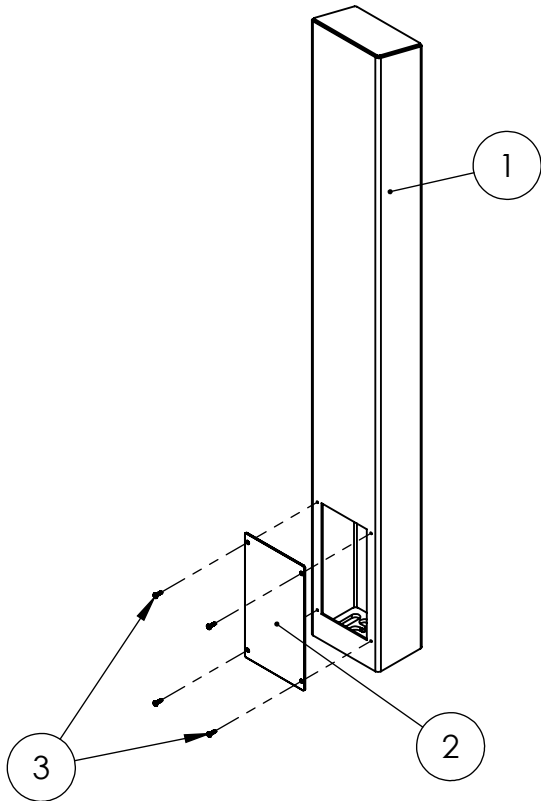

NOTES:

1. SEE STANDARD PREPARATION AND COATING INSTRUCTIONS FOR COATING PROCEDURE AND COLOR
2. SEE STANDARD PACKAGING INSTRUCTIONS FOR PACKAGING PROCEDURE



PEDESTALPRO.COM
1-800-660-3072

UNLESS OTHERWISE SPECIFIED:

DIMENSIONS ARE IN INCHES
TOLERANCES:
FRACTIONAL $\pm 1/32$
ANGULAR: $\pm 2^\circ$
TWO PLACE DECIMAL ± 0.010
THREE PLACE DECIMAL ± 0.005

INTERPRET GEOMETRIC TOLERANCING PER: ASME Y14.5 -2009

| NAME | DATE |
|--|------|
| DRAWN | |
| CHECKED | |
| PROPRIETARY AND CONFIDENTIAL | |
| THE INFORMATION CONTAINED IN THIS DRAWING IS THE SOLE PROPERTY OF PEDESTALPRO LLC. ANY REPRODUCTION IN PART OR AS A WHOLE WITHOUT THE WRITTEN PERMISSION OF PEDESTALPRO LLC IS PROHIBITED. | |

| | | | | |
|--------------------------------------|--|------------------|-------------------------------|-----------------|
| TITLE: ASSEMBLY | | SIZE A | PART NO. 64TOW-VIKI-06-304 | REV B |
| Tuesday, October 23, 2018 1:52:42 PM | | NO SCALE | | SHEET 2 OF 7 |
| WEIGHT: | | | | |