

2N VERSO 3 MODULE  
CUTOUT  
(REQUIRES 2N  
PART #  
01282-001, 01286-001)

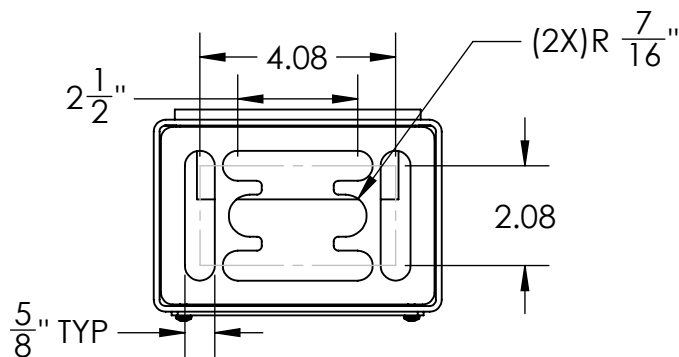

NOTES:

1. 1/2"  $\phi$  MOUNTING HARDWARE IS RECOMMENDED FOR 5X5 BASEPLATE AND STAINLESS TOWER MODELS. L-BOLT-500, STUD-ANCHOR-500.
2. 5/8"  $\phi$  MOUNTING HARDWARE IS RECOMMENDED FOR 8X8 BASEPLATE, 12X12 BASEPLATE, AND BOLLARD STYLE BASEPLATE MODELS. L-BOLT-625, STUD-ANCHOR-625.
3. MATERIAL OF CONSTRUCTION IS 304SS BRUSHED #4 FINISH.

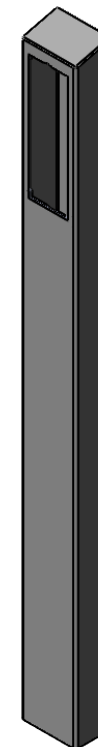
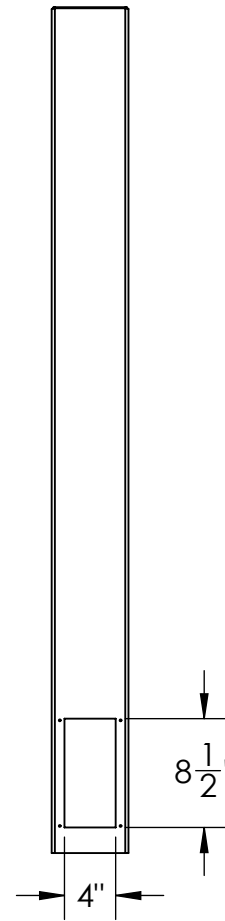
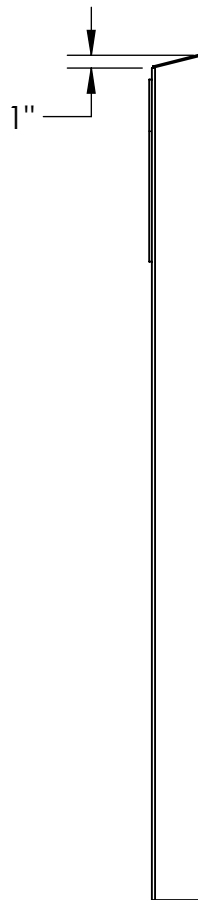
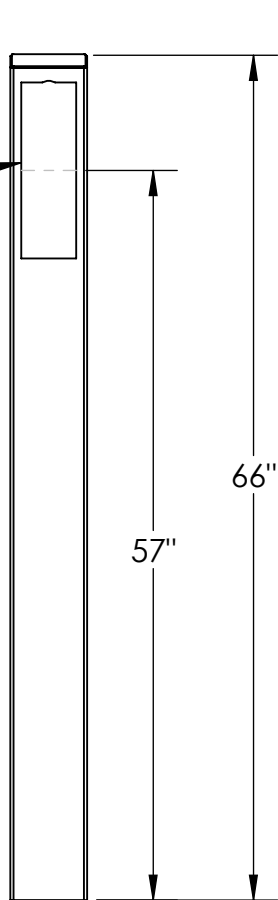

PEDESTALPRO.COM  
1-800-660-3072

UNLESS OTHERWISE SPECIFIED:

DIMENSIONS ARE IN INCHES  
TOLERANCES:  
FRACTIONAL  $\pm 1/32$   
ANGULAR:  $\pm 2^\circ$   
TWO PLACE DECIMAL  $\pm 0.010$   
THREE PLACE DECIMAL  $\pm 0.005$

INTERPRET GEOMETRIC  
TOLERANCING PER:  
ASME Y14.5 -2009

NAME	DATE
DRAWN	
CHECKED	
<b>PROPRIETARY AND CONFIDENTIAL</b>	
THE INFORMATION CONTAINED IN THIS DRAWING IS THE SOLE PROPERTY OF PEDESTALPRO LLC. ANY REPRODUCTION IN PART OR AS A WHOLE WITHOUT THE WRITTEN PERMISSION OF PEDESTALPRO LLC IS PROHIBITED.	

TITLE:		SIZE		PART NO.		REV	
INSTALLATION		A		64TOW-PRO-002-304		B	
Tuesday, October 23, 2018 1:52:42 PM		NO SCALE		SHEET 1 OF 8			
WEIGHT:							

ITEM NO.	PART NUMBER	DESCRIPTION	QTY.
1	64TOW-PRO-001-304	304SS 66" BODY	1
2	PLTACC-610	304SS STND 4X8.5 ACCESS COVER	1
3	--	8-32X5/8 SS BUTTON HEAD SCREW	4

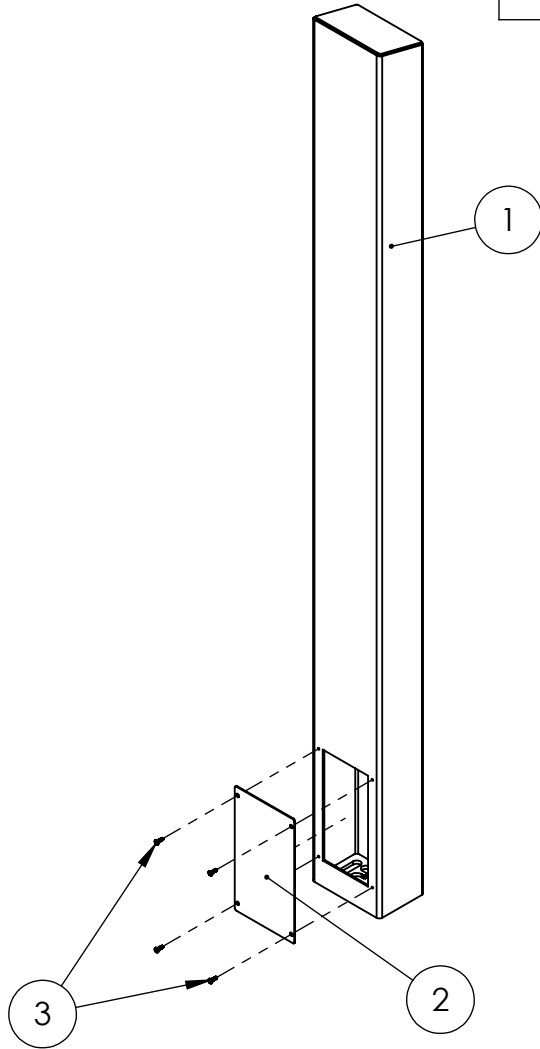

NOTES:

1. SEE STANDARD PREPARATION AND COATING INSTRUCTIONS FOR COATING PROCEDURE AND COLOR
2. SEE STANDARD PACKAGING INSTRUCTIONS FOR PACKAGING PROCEDURE



PEDESTALPRO.COM  
1-800-660-3072

UNLESS OTHERWISE SPECIFIED:

DIMENSIONS ARE IN INCHES  
TOLERANCES:  
FRACTIONAL  $\pm 1/32$   
ANGULAR:  $\pm 2^\circ$   
TWO PLACE DECIMAL  $\pm 0.010$   
THREE PLACE DECIMAL  $\pm 0.005$

INTERPRET GEOMETRIC TOLERANCING PER: ASME Y14.5 -2009

NAME	DATE
DRAWN	
CHECKED	

**PROPRIETARY AND CONFIDENTIAL**  
THE INFORMATION CONTAINED IN THIS DRAWING IS THE SOLE PROPERTY OF PEDESTALPRO LLC. ANY REPRODUCTION IN PART OR AS A WHOLE WITHOUT THE WRITTEN PERMISSION OF PEDESTALPRO LLC IS PROHIBITED.

TITLE: <b>ASSEMBLY</b>		SIZE <b>A</b>	PART NO. 64TOW-PRO-002-304	REV <b>B</b>
Tuesday, October 23, 2018 1:52:42 PM		NO SCALE		SHEET 2 OF 8
WEIGHT:				