

A8207-VE MK2  
RECESSED MOUNT

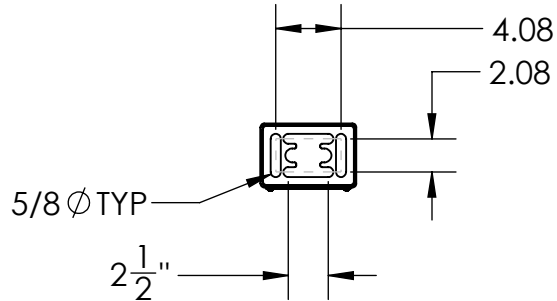

NOTES:

1. MATERIALS OF CONSTRUCTION IS 304 SS. BRUSHED #4
2. CUSTOMER NEEDS TO SUPPLY AXIS TA8201 RECESSED MOUNT KIT



PEDESTALPRO.COM  
1-800-660-3072

UNLESS OTHERWISE SPECIFIED:

DIMENSIONS ARE IN INCHES  
TOLERANCES:  
FRACTIONAL  $\pm 1/32$   
ANGULAR:  $\pm 2^\circ$   
TWO PLACE DECIMAL  $\pm 0.010$   
THREE PLACE DECIMAL  $\pm 0.005$

INTERPRET GEOMETRIC  
TOLERANCING PER:  
ASME Y14.5 -2009

NAME	DATE
DRAWN	
CHECKED	

PROPRIETARY AND CONFIDENTIAL

THE INFORMATION CONTAINED IN THIS DRAWING IS THE SOLE PROPERTY OF PEDESTALPRO LLC. ANY REPRODUCTION IN PART OR AS A WHOLE WITHOUT THE WRITTEN PERMISSION OF PEDESTALPRO LLC IS PROHIBITED.

TITLE:  
**INSTALLATION**

Tuesday, October 23,  
2018 1:52:42 PM

WEIGHT:

SIZE <b>A</b>	PART NO. 64TOW-AXIS-05-304
------------------	-------------------------------

REV <b>B</b>
-----------------

NO SCALE

SHEET 1 OF 7

ITEM NO.	PART NUMBER	DESCRIPTION	QTY.
1	PLTCAP-46-46-30	CAP PLATE	1
2	64TOW-AXIS-05-304 TUBE	VERTICAL TUBE	1
3	PLTBAS-46-46	BASE PLATE	1
4	PLTACC-510	ACCESS PANEL	1
5	--	8-32 SS BUTTON HEAD SCREW	4

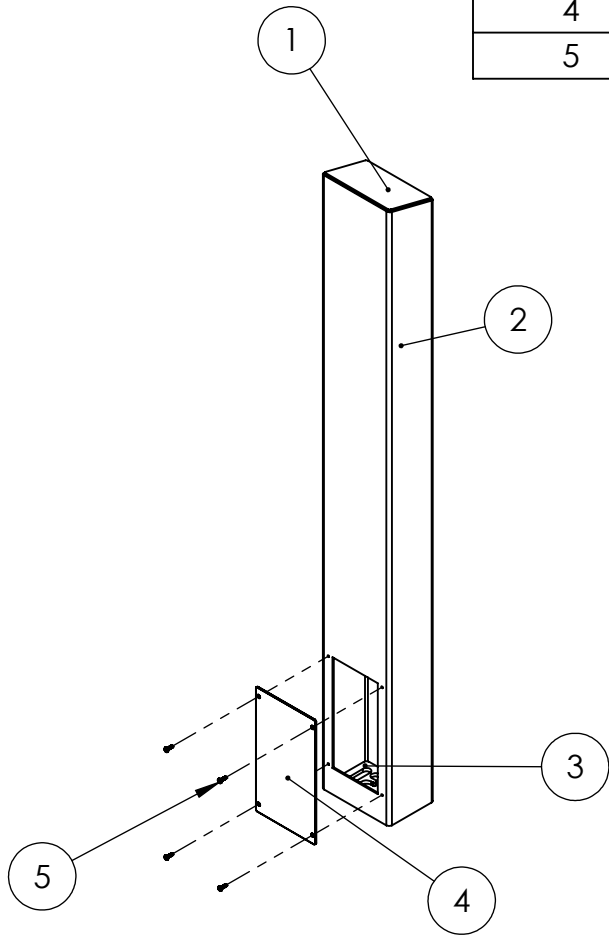

NOTES:

1. SEE STANDARD PREPARATION AND COATING INSTRUCTIONS FOR COATING PROCEDURE AND COLOR
2. SEE STANDARD PACKAGING INSTRUCTIONS FOR PACKAGING PROCEDURE



PEDESTALPRO.COM  
1-800-660-3072

UNLESS OTHERWISE SPECIFIED:

DIMENSIONS ARE IN INCHES  
TOLERANCES:  
FRACTIONAL  $\pm 1/32$   
ANGULAR:  $\pm 2^\circ$   
TWO PLACE DECIMAL  $\pm 0.010$   
THREE PLACE DECIMAL  $\pm 0.005$

INTERPRET GEOMETRIC TOLERANCING PER: ASME Y14.5 -2009

NAME	DATE
DRAWN	
CHECKED	

**PROPRIETARY AND CONFIDENTIAL**  
THE INFORMATION CONTAINED IN THIS DRAWING IS THE SOLE PROPERTY OF PEDESTALPRO LLC. ANY REPRODUCTION IN PART OR AS A WHOLE WITHOUT THE WRITTEN PERMISSION OF PEDESTALPRO LLC IS PROHIBITED.

TITLE: <b>ASSEMBLY</b>		SIZE <b>A</b>	PART NO. 64TOW-AXIS-05-304	REV <b>B</b>
Tuesday, October 23, 2018 1:52:42 PM		NO SCALE		SHEET 2 OF 7
WEIGHT:				