

SECTION A-A

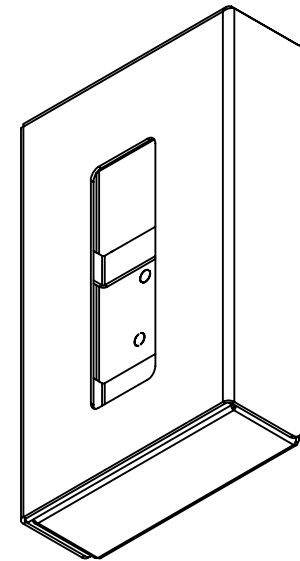
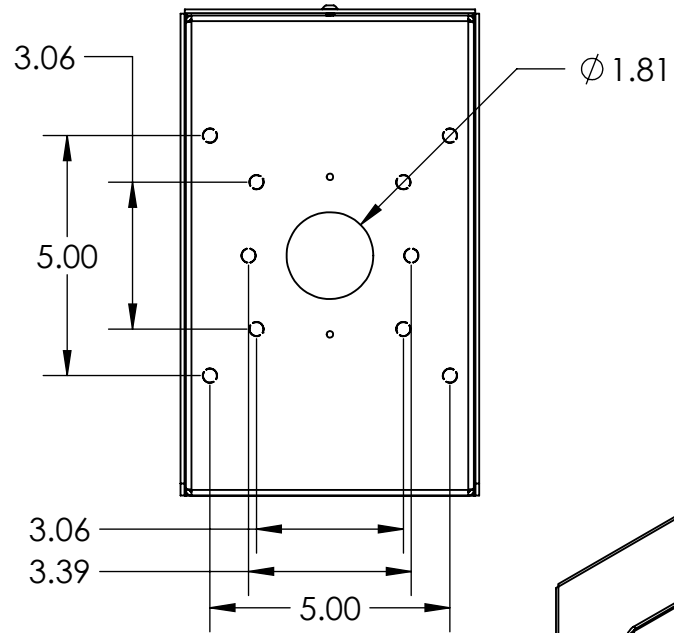

OPENPATH LIGHT

NOTES:

1. MATERIAL OF CONSTRUCTION IS MILD STEEL COATED IN 2-4 MILS BLACK WRINKLE POWDER COATING.

PEDESTALPRO.COM  
1-800-660-3072

UNLESS OTHERWISE SPECIFIED:

DIMENSIONS ARE IN INCHES  
TOLERANCES:  
FRACTIONAL  $\pm 1/32$   
ANGULAR:  $\pm 2^\circ$   
TWO PLACE DECIMAL  $\pm 0.010$   
THREE PLACE DECIMAL  $\pm 0.005$

INTERPRET GEOMETRIC  
TOLERANCING PER:  
ASME Y14.5 -2009

NAME	DATE
DRAWN	
CHECKED	

**PROPRIETARY AND CONFIDENTIAL**  
THE INFORMATION CONTAINED IN THIS DRAWING IS THE SOLE PROPERTY OF PEDESTALPRO LLC. ANY REPRODUCTION IN PART OR AS A WHOLE WITHOUT THE WRITTEN PERMISSION OF PEDESTALPRO LLC IS PROHIBITED.

TITLE:  
**INSTALLATION**

Tuesday, September 14, 2021

WEIGHT: 5.609

SIZE	PART NO.	REV
<b>A</b>	610HOU-OPEN-02-CRS	<b>0</b>
NO SCALE		SHEET 1 OF 6

ITEM NO.	PART NUMBER	DESCRIPTION	QTY.
1	610HOU-OPEN-02-CRS ENCLOSURE	ENCLOSURE WELDMENT	1
2	HINGE	PIANO HINGE	1
3	610HOU-OPEN-02-CRS DOOR	DOOR WELDMENT	1
4	GASKET SIDE	3/8" X .150 WEATHERSTRIPPING	2
5	GASKET TOP	3/8" X .150 WEATHERSTRIPPING	1
6	--	6-32 PAN HEAD SCREW	2
7	--	6-32 EXTERNAL TOOTH LOCK NUT	2
8	610HOU-OPEN-02-CRS BRACKET	DEVICE BRACKET	1
9	--	8-32 SS TORX SECURITY SCREW	1
10	--	8-32 X 1/2 SS PEM STUD	4
11	--	8-32 SS NYLON LOCK NUT	4

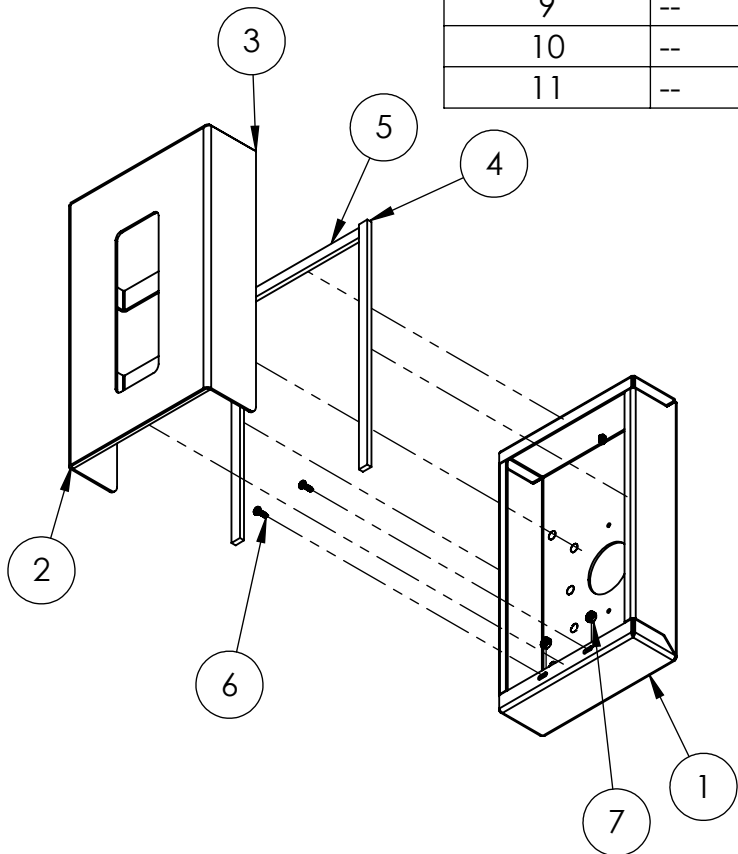

NOTES:

- SEE STANDARD PREPARATION AND COATING INSTRUCTIONS FOR COATING PROCEDURE AND COLOR.
- SEE STANDARD PACKAGING INSTRUCTIONS FOR PACKAGING PROCEDURE.

UNLESS OTHERWISE SPECIFIED:

DIMENSIONS ARE IN INCHES  
TOLERANCES:  
FRACTIONAL  $\pm 1/32$   
ANGULAR:  $\pm 2^\circ$   
TWO PLACE DECIMAL  $\pm 0.010$   
THREE PLACE DECIMAL  $\pm 0.005$

INTERPRET GEOMETRIC  
TOLERANCING PER:  
ASME Y14.5 -2009

NAME DATE

DRAWN

CHECKED

**PROPRIETARY AND CONFIDENTIAL**

THE INFORMATION CONTAINED IN THIS  
DRAWING IS THE SOLE PROPERTY OF  
PEDESTALPRO LLC. ANY REPRODUCTION  
IN PART OR AS A WHOLE WITHOUT THE  
WRITTEN PERMISSION OF PEDESTALPRO LLC  
IS PROHIBITED.

TITLE:

**ASSEMBLY**

Tuesday, August 4,  
2020 1:54:51 PM

WEIGHT: 5.609

SIZE  
**A**

PART NO.  
610HOU-OPEN-02-CRS

REV  
**0**

NO SCALE

SHEET 2 OF 6

PEDESTALPRO.COM  
1-800-660-3072