

NOTES:

1. 5/8" ϕ MOUNTING HARDWARE IS RECOMMENDED.
2. MOUNTS THE BUTTERFLY MX 7 INCH SURFACE MOUNT UNIT.
3. COATED IN 2 MILS OF ZINC ENRICHED PRIMER AND 2-4 MILS OF COLOR MATCHED POWDER COAT.



PEDESTALPRO.COM
1-800-660-3072

UNLESS OTHERWISE SPECIFIED:

DIMENSIONS ARE IN INCHES
TOLERANCES:
FRACTIONAL: $\pm 1/32$
ANGULAR: $\pm 2^\circ$
TWO PLACE DECIMAL ± 0.010
THREE PLACE DECIMAL ± 0.005

INTERPRET GEOMETRIC
TOLERANCING PER:
ASME Y14.5 -2009

NAME	DATE
DRAWN	
CHECKED	

PROPRIETARY AND CONFIDENTIAL

THE INFORMATION CONTAINED IN THIS DRAWING IS THE SOLE PROPERTY OF PEDESTALPRO LLC. ANY REPRODUCTION IN PART OR AS A WHOLE WITHOUT THE WRITTEN PERMISSION OF PEDESTALPRO LLC IS PROHIBITED.

TITLE:
INSTALLATION

Wednesday, January
23, 2019 10:46:39 AM

WEIGHT:

SIZE	PART NO.	REV
A	33PED-BUT-002-CRS	0
NO SCALE		SHEET 1 OF 6

ITEM NO.	PART NUMBER	DESCRIPTION	QTY.
1	33PED-BUT-002-CRS	3X3 STEEL TUBE	1
2	BACK PLATE 7S	7 INCH BMX BACK PLATE	1
3	FACE PLATE 7S	7 INCH BMX FACE PLATE	1
4	BASE PLATE 8 281	8" STANDARD BASE PLATE	1
5	COVER PLATE 8 3125	8" STANDARD COVER PLATE	1
6	KEYHOLE STUD	8MM KEYHOLE STUD	3

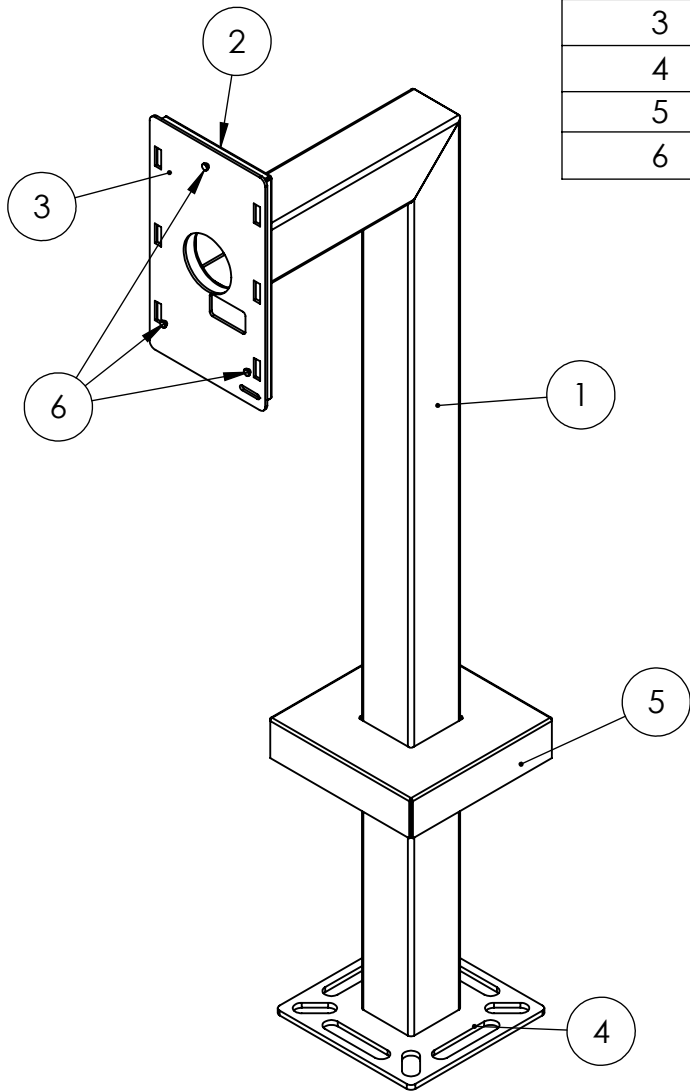

NOTES:

1. BUTT WELDED SECTIONS ARE NOT ALLOWED, EACH SECTION OF TUBE MUST BE FROM CONTINUOUS STOCK.
2. ALL WELDS ARE TO BE CONTINUOUS FILLET WELDS UNLESS NOTED OTHERWISE.
3. SEE STANDARD PREPARATION AND COATING INSTRUCTIONS FOR COATING PROCEDURE AND COLOR.
4. FASTENERS ARE TO BE BAGGED AND SHIPPED WITH PEDESTAL.
5. SEE STANDARD PACKAGING INSTRUCTIONS FOR PACKAGING PROCEDURE.



PEDESTALPRO.COM
1-800-660-3072

UNLESS OTHERWISE SPECIFIED:

DIMENSIONS ARE IN INCHES
TOLERANCES:
FRACTIONAL $\pm 1/32$
ANGULAR: $\pm 2^\circ$
TWO PLACE DECIMAL ± 0.010
THREE PLACE DECIMAL ± 0.005

INTERPRET GEOMETRIC
TOLERANCING PER:
ASME Y14.5 -2009

NAME	DATE
DRAWN	
CHECKED	
PROPRIETARY AND CONFIDENTIAL	
THE INFORMATION CONTAINED IN THIS DRAWING IS THE SOLE PROPERTY OF PEDESTALPRO LLC. ANY REPRODUCTION IN PART OR AS A WHOLE WITHOUT THE WRITTEN PERMISSION OF PEDESTALPRO LLC IS PROHIBITED.	

TITLE: ASSEMBLY		DATE: Wednesday, January 23, 2019 10:46:39 AM	SIZE: A	PART NO. 33PED-BUT-002-CRS	REV 0
WEIGHT:		NO SCALE		SHEET 2 OF 6	