

**NOTES:**

1. 5/8"  $\phi$  MOUNTING HARDWARE IS RECOMMENDED.
2. MOUNTS THE BUTTERFLY MX 7 INCH SURFACE MOUNT UNIT.



PEDESTALPRO.COM  
1-800-660-3072

UNLESS OTHERWISE SPECIFIED:

DIMENSIONS ARE IN INCHES  
TOLERANCES:  
FRACTIONAL  $\pm 1/32$   
ANGULAR:  $\pm 2^\circ$   
TWO PLACE DECIMAL  $\pm 0.010$   
THREE PLACE DECIMAL  $\pm 0.005$

INTERPRET GEOMETRIC  
TOLERANCING PER:  
ASME Y14.5 -2009

NAME	DATE
DRAWN	
CHECKED	

**PROPRIETARY AND CONFIDENTIAL**  
THE INFORMATION CONTAINED IN THIS DRAWING IS THE SOLE PROPERTY OF PEDESTALPRO LLC. ANY REPRODUCTION IN PART OR AS A WHOLE WITHOUT THE WRITTEN PERMISSION OF PEDESTALPRO LLC IS PROHIBITED.

TITLE:  
**INSTALLATION**

Wednesday, January 23, 2019 10:46:39 AM

SIZE <b>A</b>	PART NO. 33PED-BUT-002-304	REV <b>0</b>
------------------	-------------------------------	-----------------

WEIGHT: NO SCALE SHEET 1 OF 6

ITEM NO.	PART NUMBER	DESCRIPTION	QTY.
1	33PED-BUT-002-304	3X3 304 SS TUBE	1
2	BACK PLATE 7S	7 INCH BMX BACK PLATE	1
3	FACE PLATE 7S	7 INCH BMX FACE PLATE	1
4	BASE PLATE 8 281	8" STANDARD BASE PLATE	1
5	COVER PLATE 8 3125	8" STANDARD COVER PLATE	1
6	KEYHOLE STUD	8MM KEYHOLE STUD	3

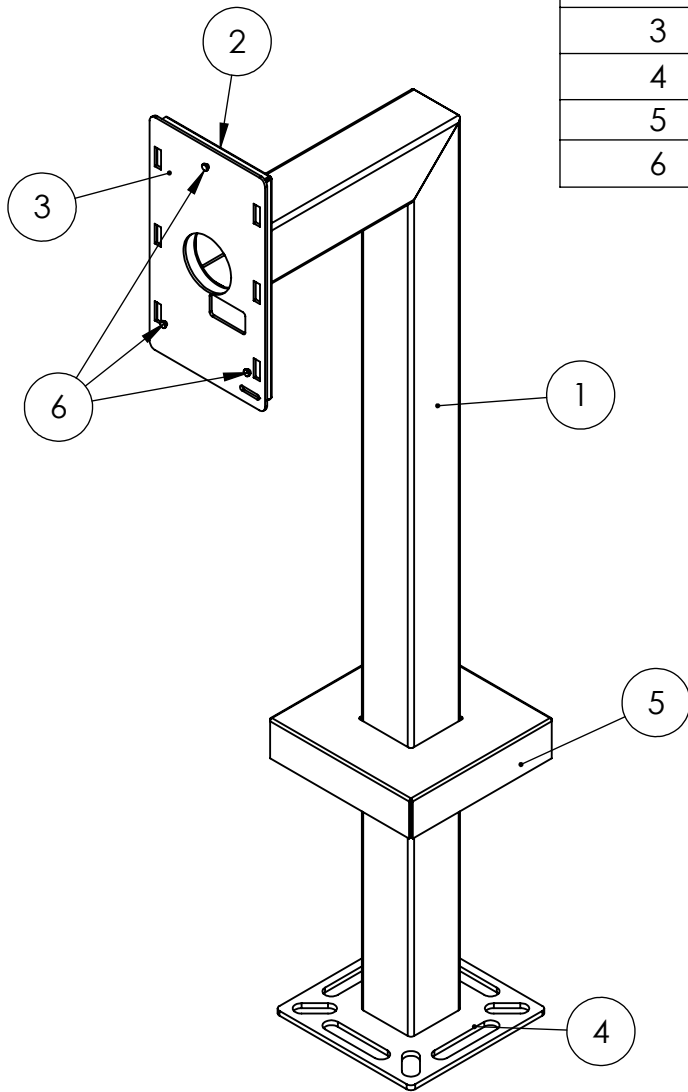

NOTES:

1. BUTT WELDED SECTIONS ARE NOT ALLOWED, EACH SECTION OF TUBE MUST BE FROM CONTINUOUS STOCK.
2. ALL WELDS ARE TO BE CONTINUOUS FILLET WELDS UNLESS NOTED OTHERWISE.
3. SEE STANDARD PREPARATION AND COATING INSTRUCTIONS FOR COATING PROCEDURE AND COLOR.
4. FASTENERS ARE TO BE BAGGED AND SHIPPED WITH PEDESTAL.
5. SEE STANDARD PACKAGING INSTRUCTIONS FOR PACKAGING PROCEDURE.



PEDESTALPRO.COM  
1-800-660-3072

UNLESS OTHERWISE SPECIFIED:

DIMENSIONS ARE IN INCHES  
TOLERANCES:  
FRACTIONAL  $\pm 1/32$   
ANGULAR:  $\pm 2^\circ$   
TWO PLACE DECIMAL  $\pm 0.010$   
THREE PLACE DECIMAL  $\pm 0.005$

INTERPRET GEOMETRIC  
TOLERANCING PER:  
ASME Y14.5 -2009

NAME	DATE
DRAWN	
CHECKED	
<b>PROPRIETARY AND CONFIDENTIAL</b>	
THE INFORMATION CONTAINED IN THIS DRAWING IS THE SOLE PROPERTY OF PEDESTALPRO LLC. ANY REPRODUCTION IN PART OR AS A WHOLE WITHOUT THE WRITTEN PERMISSION OF PEDESTALPRO LLC IS PROHIBITED.	

TITLE:		SIZE	PART NO.	REV
ASSEMBLY		<b>A</b>	33PED-BUT-002-304	0
Wednesday, January 23, 2019 10:46:39 AM		NO SCALE		SHEET 2 OF 6
WEIGHT:				