

DETAIL A

NOTES:  
 1. MATERIAL OF CONSTRUCTION IS MILD STEEL COATED IN 2-4 MILS FLAT BLACK WITH ZINC ENRICHED PRIMER.



PEDESTALPRO.COM  
 1-800-660-3072

UNLESS OTHERWISE SPECIFIED:

DIMENSIONS ARE IN INCHES  
 TOLERANCES:  
 FRACTIONAL:  $\pm 1/32$   
 ANGULAR:  $\pm 2^\circ$   
 TWO PLACE DECIMAL:  $\pm 0.010$   
 THREE PLACE DECIMAL:  $\pm 0.005$

INTERPRET GEOMETRIC TOLERANCING PER: ASME Y14.5 -2009

NAME	DATE
DRAWN	
CHECKED	

**PROPRIETARY AND CONFIDENTIAL**  
 THE INFORMATION CONTAINED IN THIS DRAWING IS THE SOLE PROPERTY OF PEDESTALPRO LLC. ANY REPRODUCTION IN PART OR AS A WHOLE WITHOUT THE WRITTEN PERMISSION OF PEDESTALPRO LLC IS PROHIBITED.

TITLE:  
**INSTALLATION**

Friday, July 17, 2020  
 12:27:33 PM

WEIGHT: 36.765

SIZE	PART NO.	REV
<b>A</b>	33PE1-INVU-01-CRS	<b>0</b>
NO SCALE		SHEET 1 OF 4

ITEM NO.	PART NUMBER	DESCRIPTION	QTY.
1	33PE1-INVU-01-CRS	3 X 3 WELDMENT	1
2	PLTBAS-8-3	8" STANDARD BASE PLATE	1
3	PLTCOV-8-3	STANDARD COVER PLATE	1
4	33PE1-INVU-01-CRS FACE	CUSTOM INVICTUS FACE PLATE	1
5	--	1/4-20 X .5 ZINC PL CARRIAGE BOLT	4
6	--	1/4-20 ZINC PL HEX NUT	4

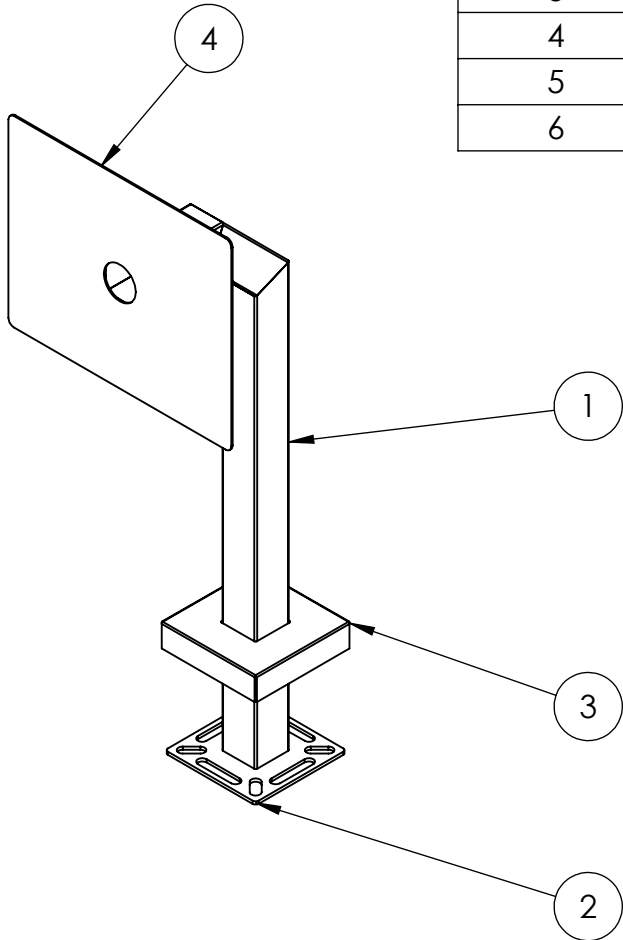

NOTES:

1. SEE STANDARD PREPARATION AND COATING INSTRUCTIONS FOR COATING PROCEDURE AND COLOR.
2. SEE STANDARD PACKAGING INSTRUCTIONS FOR PACKAGING PROCEDURE.

UNLESS OTHERWISE SPECIFIED:

DIMENSIONS ARE IN INCHES  
TOLERANCES:  
FRACTIONAL  $\pm 1/32$   
ANGULAR:  $\pm 2^\circ$   
TWO PLACE DECIMAL  $\pm 0.010$   
THREE PLACE DECIMAL  $\pm 0.005$

INTERPRET GEOMETRIC  
TOLERANCING PER:  
ASME Y14.5 -2009

NAME DATE

DRAWN

CHECKED

**PROPRIETARY AND CONFIDENTIAL**

THE INFORMATION CONTAINED IN THIS  
DRAWING IS THE SOLE PROPERTY OF  
PEDESTALPRO LLC. ANY REPRODUCTION  
IN PART OR AS A WHOLE WITHOUT THE  
WRITTEN PERMISSION OF PEDESTALPRO LLC  
IS PROHIBITED.

TITLE:

**ASSEMBLY**

Friday, July 17, 2020  
12:27:33 PM

WEIGHT: 36.765

SIZE  
**A**

PART NO.  
33PE1-INVU-01-CRS

REV  
**0**

NO SCALE

SHEET 2 OF 4

PEDESTALPRO.COM  
1-800-660-3072