

- NOTES:
- 1/2" ϕ MOUNTING HARDWARE IS RECOMMENDED FOR 5X5 BASEPLATE MODELS. L-BOLT-500, STUD-ANCHOR-500.
 - 5/8" ϕ MOUNTING HARDWARE IS RECOMMENDED FOR 8X8 AND 12X12 BASEPLATE MODELS. L-BOLT-625, STUD-ANCHOR-625



PEDESTALPRO.COM
1-800-660-3072

UNLESS OTHERWISE SPECIFIED:
DIMENSIONS ARE IN INCHES
TOLERANCES:
FRACTIONAL $\pm 1/32$
ANGULAR: $\pm 2^\circ$
TWO PLACE DECIMAL ± 0.010
THREE PLACE DECIMAL ± 0.005
INTERPRET GEOMETRIC TOLERANCING PER: ASME Y14.5 -2009

NAME	DATE
DRAWN	
CHECKED	
PROPRIETARY AND CONFIDENTIAL	
THE INFORMATION CONTAINED IN THIS DRAWING IS THE SOLE PROPERTY OF PEDESTALPRO LLC. ANY REPRODUCTION IN PART OR AS A WHOLE WITHOUT THE WRITTEN PERMISSION OF PEDESTALPRO LLC IS PROHIBITED.	

TITLE: INSTALLATION		SIZE A	PART NO. 33PE1-2NIP-04-304	REV B
Thursday, October 25, 2018 3:57:46 PM		NO SCALE		SHEET 1 OF 4
WEIGHT:				

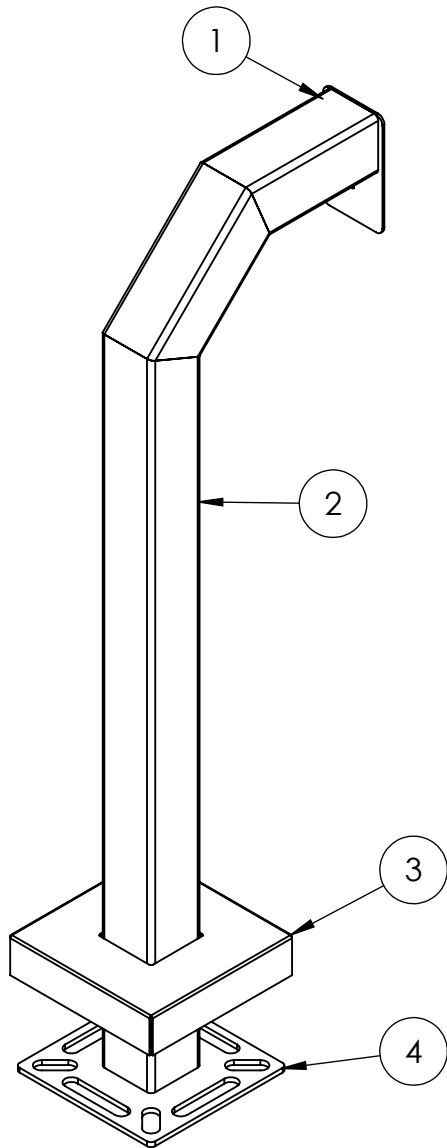

ITEM NO.	PART NUMBER	DESCRIPTION	QTY.
1	PLTFAC-3-4	MOUNTING PLATE	1
2	42-3-12-SS	3X3 SQ 304SS TUBE	1
3	PLTCOV-8-3	8" STANDARD 304SS COVER PLATE	1
4	PLTBAS-8-3	8" STANDARD 304SS BASE PLATE	1
5	--	1/4-20 X .50 ZINC PL CARRIAGE BOLT	4
6	--	1/4-20 ZINC PL HEX NUT	4

NOTES:

1. BUTT WELDED SECTIONS ARE NOT ALLOWED, EACH SECTION OF TUBE MUST BE FROM CONTINUOUS STOCK.
2. ALL WELDS ARE TO BE CONTINUOUS FILLET WELDS UNLESS NOTED OTHERWISE.
3. SEE STANDARD PREPARATION AND COATING INSTRUCTIONS FOR COATING PROCEDURE AND COLOR.
4. FASTENERS ARE TO BE BAGGED AND SHIPPED WITH PEDESTAL.
5. SEE STANDARD PACKAGING INSTUCTIONS FOR PACKAGING PROCEDURE.



PEDESTALPRO.COM
1-800-660-3072

UNLESS OTHERWISE SPECIFIED:

DIMENSIONS ARE IN INCHES
TOLERANCES:
FRACTIONAL $\pm 1/32$
ANGULAR: $\pm 2^\circ$
TWO PLACE DECIMAL ± 0.010
THREE PLACE DECIMAL ± 0.005

INTERPRET GEOMETRIC
TOLERANCING PER:
ASME Y14.5 -2009

NAME	DATE
DRAWN	
CHECKED	

PROPRIETARY AND CONFIDENTIAL

THE INFORMATION CONTAINED IN THIS DRAWING IS THE SOLE PROPERTY OF PEDESTALPRO LLC. ANY REPRODUCTION IN PART OR AS A WHOLE WITHOUT THE WRITTEN PERMISSION OF PEDESTALPRO LLC IS PROHIBITED.

TITLE:
ASSEMBLY

Thursday, October 25,
2018 3:57:46 PM

WEIGHT:

SIZE	PART NO.	REV
A	33PE1-2NIP-04-304	B

NO SCALE

SHEET 2 OF 4