

Parking Pro

Car park barrier

mAGNETIC[®]
ACCESS TO PROGRESS



For heavily frequented parking facilities

In a multi-storey car park or an underground garage, Parking Pro barriers from Magnetic are the ideal solution for professional parking applications. Thanks to their configuration and security settings, Parking Pro barriers are designed for use in heavily frequented facilities in which the movement of persons can be ruled out. Rapid opening times and the detection of tailgating vehicles ensure reliable processing for users, while low energy consumption, low-maintenance components and simple servicing keeps running costs down permanently. The barrier booms are

optimised for use in parking applications: with the boom break-away option, for example, the boom is completely jettisoned in the case of a forced unauthorised passage – and it can be re-attached again without any impairment of function. In addition, visibility can be further increased by means of lighting elements and an expansion set. At the heart of the car park barrier is the innovative MHTM™ drive, characterised by its energy efficiency, lack of maintenance, and long service life – the Parking Pro is designed for 10 million opening and closing cycles.



Professional parking solution

The Parking Pro is the first choice for operators of multi-storey car parks and solution suppliers thanks to its rapid opening times, low operating costs, easy handling, great reliability and extraordinarily long service life.



Innovative drive technology

The MHTM™ drive unit operates without maintenance, energy-efficiently and quietly. Its high torque ensures best possible operation even under extreme weather conditions.



Legal security

All barriers from Magnetic have a conformity declaration in line with the Machinery Directive and a performance declaration according to the EU's Construction Products Regulation. So operators and installers are always on the safe side regarding liability issues.



Easy access to components

Two simple hand movements suffice: easy access to the control system and drive unit by removing the hood and front panel. This increases user-friendliness and speeds up commissioning and servicing.

Parking Pro

Car park barrier

- > Reliable detection of tailgating vehicles
- > Low power consumption for economical operation
- > Optimum accessibility for particularly easy maintenance
- > German Design Award 2014 and red dot design award 2012
- > Designed for 10 million opening and closing cycles

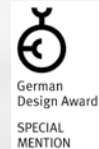

Technical data	Parking Pro
Barrier width	max. 3.5 m
Opening/closing time	1.3 s
Power consumption	max. 95 W
Drive technology	MHTM™
Voltage	85–264 VAC, 50/60 Hz
Duty cycle	100%
Housing dimensions (W x D x H)	315 x 360 x 915 mm
Enclosure rating	IP54
Temperature range	–30 to +55° C
Weight	40 kg

Features	Parking Pro
Standard colours	RAL 2000, 9006, 9007
VarioBoom barrier boom	Standard
Control system	MGC Pro
Integrated 2-channel detector for induction loops	Standard
Modular expansion of control system	Standard
Variable I/O assignment	Standard
No. of digital inputs	8
No. of relays/digital outputs	6/4
Selectable closing speed	Standard
Selectable opening speed	Standard

Options	Parking Pro
Special colours	✓
Folding boom	✓
Boom extension set	✓
Support post	✓
Breakaway flange	✓
Boom drop contact	✓
Boom interlock	✓
Boom lighting, red	✓
Illumination strip, red/green	✓
Cover illumination	✓
Key-operated switch	✓
Radio module	✓
Ethernet module	✓
RS485 module	✓
CAN module (counting)	✓
Second detector module	✓
GSM module	✓
Photoelectric safety switch	✓
Battery backup	✓

Standard colours

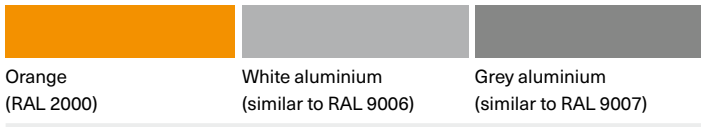

Dimensional drawings

Parking Pro with VarioBoom

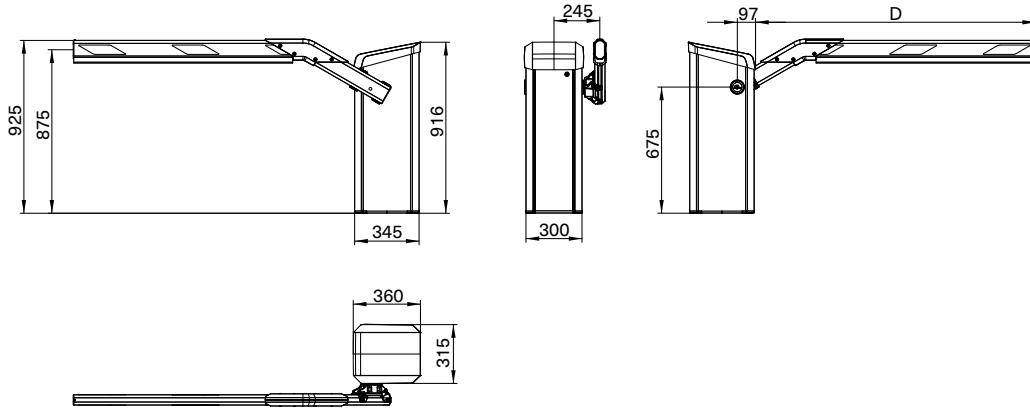

Parking Pro with VarioBoom and optional expansion set

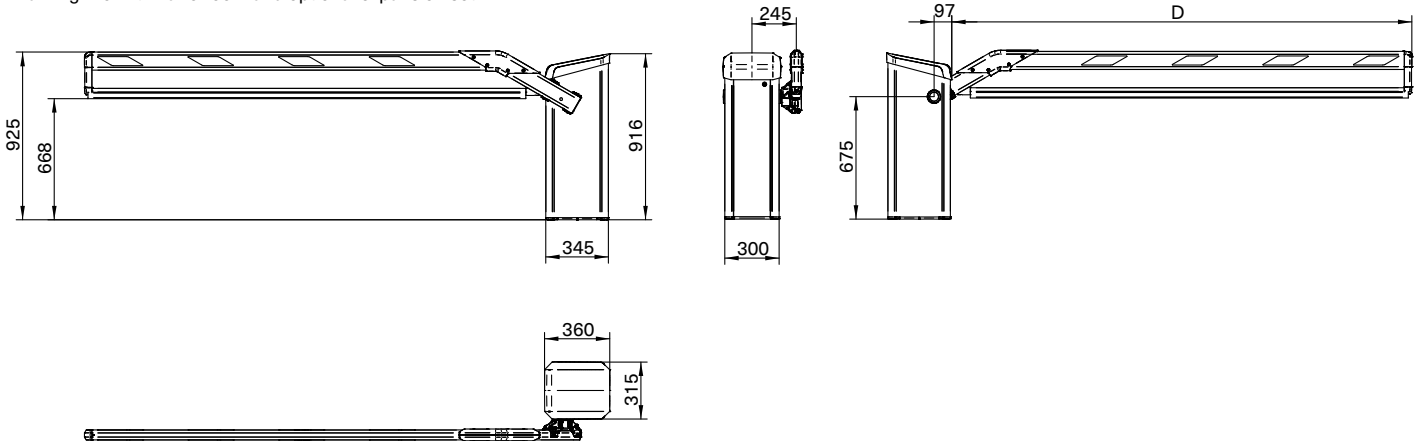

Parking Pro with optional folding boom

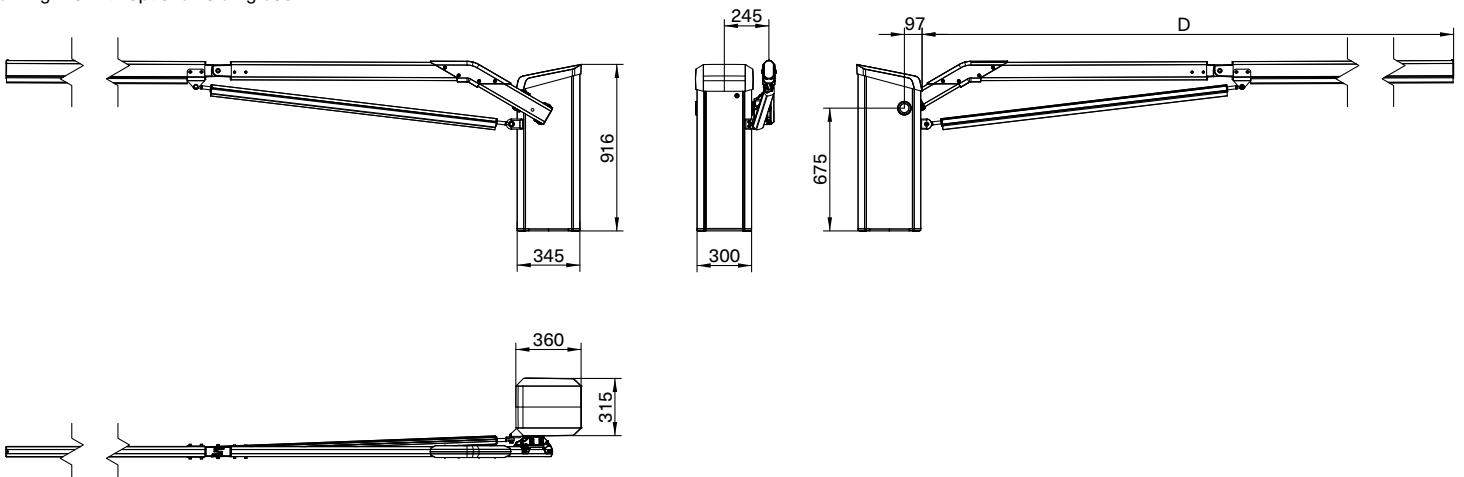

Access to Progress

Magnetic stands for pioneering products – in every way. Our access control systems for vehicles or pedestrians clear the way for thousands of people every day – at car parks, toll gates, stations, airports and in buildings. Our technology is also pioneering, however: with innovative drives, intelligent control systems and well thought-out details it provides maximum safety and longevity. Are you also on the path to Magnetic?



Vehicle barriers

- Access barriers
- Parking barriers
- Toll barriers
- Special barriers



Pedestrian gates

- Turnstiles
- Swing gates
- Tripod gates
- Retractable gates
- Wing gates



Terminals

- Cars
- Trucks

Web: www.MagneticGateOpeners.com

Phone: (800) 878-7829

Fax: (330) 650-9004

Email: sales@magneticgateopeners.com