

HID® Mercury™ LP2500 Intelligent Controller

Master intelligent controller
(no onboard I/O)

The HID Mercury LP Series Intelligent Controllers are HID Global's next generation advanced access control platform that runs on embedded Linux. The enhanced platform offers an improved processor and increased memory, plus feature an embedded crypto memory chip that provides a secured layer of encryption to onboard sensitive data. Built on the HID Mercury open platform, LP Series controllers provide the necessary flexibility for OEMs, channel partners and end customers to choose the controller configuration that best fits their needs.

The LP2500 is a powerful intelligent controller with native network support and is scalable to 64 doors/openings. Built on the HID Mercury platform, the intelligent controller uses an on-board Ethernet port to connect to cloud or server based access control hosts. The intelligent controller performs access control, alarm management and scheduled operations— all in a single package.

Capable of elaborate processes and procedures without host intervention, the intelligent controller, once programmed, can function independently of the host. System configuration and setup are provided through HID OEM partner software applications.

For partners seeking a comprehensive and open access control platform, increased user capacity, and a reliable hardware platform running an expanded set of applications, the LP2500 is the clear solution. It delivers a complete security and access control solution as well as innovative application extensions, interoperability and data security.



KEY BENEFITS:

- Open Architecture – High performance, reliable platform enables use of hardware with HID Mercury OEM partners' software solutions.
- Enhanced Security – Embedded crypto memory chip and data at rest encryption provides secured layer of protection of sensitive data.
- OSDP Protocol – Secure channel communications for reader connectivity.
- Versatile Interoperability – Same reliable interface and identical footprint as the EP Controllers, enabling seamless upgrades for existing deployments.

HIGHLIGHTS

Third Party Integration Supported

- Wireless Locks
- Power Supply Alerts and Events

Security and Network

- IPv4/v6
- Host communications protected by TLS 1.2/1.1 or AES-256/128
- Controller/IO Expansion connection protected by AES
- Generate and load custom peer certificates for TLS
- Port based network access control using 802.1X
- FIPS 140-2 user of OpenSSL

Card Reader Functions

- Encrypted database with configurable sizing
- Supports up to 19 digital card numbers
- Supports PIN codes up to 15 digits
- Up to 255 access levels per cardholder
- Card issue code (up to 32 bits), ADA and VIP flags; PIV (75 bits); Smart Card (200 bits)

HID Mercury LP2500 Intelligent Controller	
Access Control	600,000 cardholder capacity 50,000 transaction buffer Supports up to 2 RS-485 IO protocols 255 access levels per cardholder Cardholder - 19 Digit (64 Bit) User ID with 15 digit PIN MAX Activation/Deactivation If/Then macro capabilities Anti-passback support Nested, area, hard, soft and timed forgiveness Adjustable cardholder capacity Supports up to 1024 inputs or 1024 outputs
Door Control	Natively does not support any readers or openings. Use in conjunction with IO expansion modules to support up to 64 readers and openings
GENERAL	
Primary Power	12 to 24 VDC \pm 10 %, 500 mA maximum (reader and USB ports not included)
Micro USB Port	5 VDC, 500 mA maximum (add 270 mA to primary power current)
Battery	Memory/Clock Backup: 3 Volt Lithium, type BR2330 or CR2330
microSD Card	Format: microSD or microSDHC; 2GB to 8GB
Host Communication	Ethernet: 10-BaseT/100Base-TX and Micro USB port (2.0) with optional adapter: pluggable model USB2-OTGE100
Serial I/O Device	Two each: 2-wire RS-485, 2,400 to 115,200 bps, asynchronous, half-duplex, 1 start bit, 8 data bits, and 1 stop bit
Inputs	Two unsupervised dedicated for cabinet tamper and UPS fault monitoring
CABLE REQUIREMENTS	
Power and Relays	1 twisted pair, 18 to 16 AWG
Ethernet	CAT-5, minimum
RS-485	1 twisted pair, shield, 120 ohm impedance, 24 AWG. 4,000 ft. (1,219 m) maximum cable length
ENVIRONMENTAL	
Temperature	-55 to +85 °C, storage, 0 to +70 °C, operating
Humidity	5 to 95% RHNC
MECHANICAL	
Dimensions	5 in. (127 mm) W x 6 in. (152.4 mm) L x 1 in. (25 mm) H
Weight	4.1 oz. (115 gm) nominal, board only
COMPLIANCE AND WARRANTY	
Product Compliance	UL 294 Recognized, FCC Part 15 Class A, CE Compliant, RoHS (2011/65/EU & 2015/863), EU REACH (1907/2006), California Proposition 65, NIST Certified Encryption
Warranty	The product is warranted free from defects in material and workmanship under normal use and service with proper maintenance for one year from the date of factory shipment.

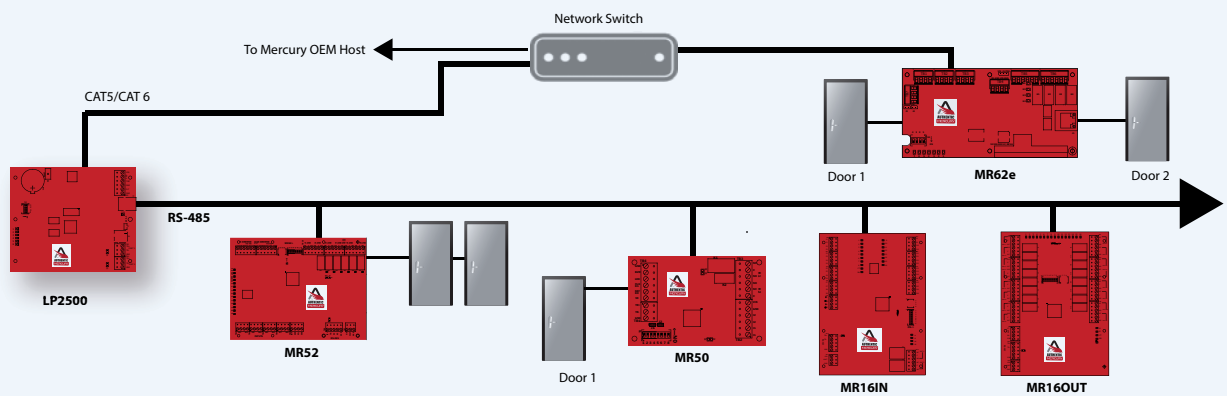

hidglobal.com

North America: +1 512 776 9000 | Toll Free: 1 800 237 7769

Europe, Middle East, Africa: +44 1440 714 850

Asia Pacific: +852 3160 9800 | Latin America: +52 (55) 9171-1108

For more global phone numbers click here

© 2022 HID Global Corporation/ASSA ABLOY AB. All rights reserved.

2019-10-15-pacs-hid-mercury-lp2500-ds-en PLT-04696

Part of ASSA ABLOY