

Access Pro-H

Access barriers for boom skirts



For special security requirements

At the entrances of companies, building sites, port facilities and other secured areas – the Access Pro-H from Magnetic is the ideal solution in all cases where traffic control is necessary and pedestrian access must also be reliably prevented. A boom skirt and climb-over prevention effectively stop intruders climbing over or crawling under the barrier. With their low impact forces, these barriers are also approved for locations where the movement of people can be expected (when the stipulated safety equipment is installed).

At the heart of the Access series is the innovative MHTM™ drive that is distinguished by its energy efficiency, lack of maintenance and long service life – the barriers of the Access series are designed for 10 million opening and closing cycles. By the way, Magnetic quality lies not just in the detail, but is also easily recognisable to all thanks to stylish design. The Access series has already been awarded two design prizes.

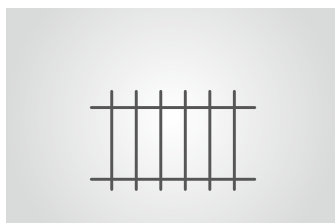

Boom skirt and climb-over prevention

The Access Pro-H not only regulates traffic but, with the optional boom skirt, also effectively stops unauthorised pedestrian access to security-relevant areas.



Innovative drive technology

The MHTM™ drive unit is maintenance-free, energy-efficient and quiet. The high torque guarantees best possible operation even under extreme weather conditions.



Legal security

All Magnetic barriers have a Declaration of Conformity in compliance with the Machinery Directive and a Declaration of Performance in line with the Construction Products Directive. Thus operators and those responsible for commissioning are always on the safe side in questions of liability.

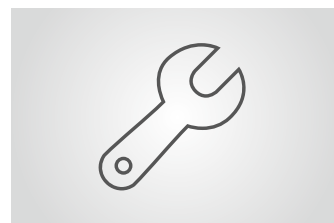

Easy access to components

Two simple steps: control systems and the drive unit are easily reached by removing the cover and front plate. This increases user-friendliness and accelerates commissioning and service.

Access Pro-H

Access barriers for boom skirts

- > High security with optional boom skirts
- > Very low operating costs thanks to efficient and long-lived MHTM™ drive
- > Ease-of-use and optimum accessibility thanks to well thought-out design
- > Legal security with Declarations of Conformity and Performance
- > Acclaimed design: German Design Award 2014 and Red Dot Design Award 2012
- > Designed for 10 million opening and closing actions



Technical data	Access Pro-H
Lane width	Max. 6.0 m
Opening/closing time	4.0 s
Power consumption	Max. 25 W
Drive technology	MHTM™
Voltage	85 – 264 VAC, 50/60 Hz
Duty cycle	100 %
Housing dimensions (W x D x H)	315 x 360 x 1115 mm
Enclosure rating	IP 54
Temperature range	-30 to +55 °C
Weight	44 kg

Features	Access Pro-H
Standard colours	RAL 2000, 9006, 9007
Barrier arm	MicroBoom
Control system	MGC Pro
Integrated 2-channel detector for induction loops	Standard
Modular expansion of control system	Standard
Variable I/O assignment	Standard
No. of digital inputs	8
No. of relays/digital outputs	6/4
Input with test for safety light barrier/Laser scanner	Standard
Selectable closing speed	Standard
Selectable opening speed	Standard

Options	Access Pro-H
Special colours	✓
Standard boom skirt ¹	✓
Boom skirt with climb-over prevention (height = 1.30 m) ²	✓
Boom skirt with climb-over prevention (height = 1.80 m) ³	✓
Pendulum support	✓
Support post	✓
Boom drop contact	✓
Boom interlock	✓
Boom illumination, red ⁴	✓
Light strips, red/green ⁵	✓
Hood light	✓
Key-operated switch	✓
Radio module	✓
Ethernet module	✓
RS485 module	✓
CAN module (counting)	✓
Second detector module	✓
GSM module	✓
Safety light barrier/Laser scanner	✓
Battery backup	✓

¹ max. 5.0 m/5.5 m lane width (PS/SP)

² max. 4.3 m/4.7 m lane width (PS/SP)

³ max. 4.0 m/4.5 m lane width (PS/SP)

PS = Pendulum support, SP = Support post

⁴ With climb-over prevention only possible on the back of the barrier boom

⁵ Not in combination with standard boom skirt

Standard colours

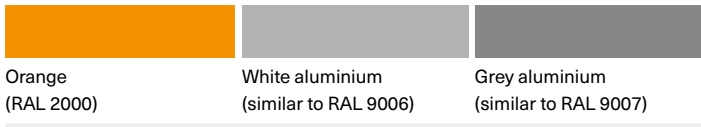

Dimensional drawings

Access Pro-H with standard boom skirt

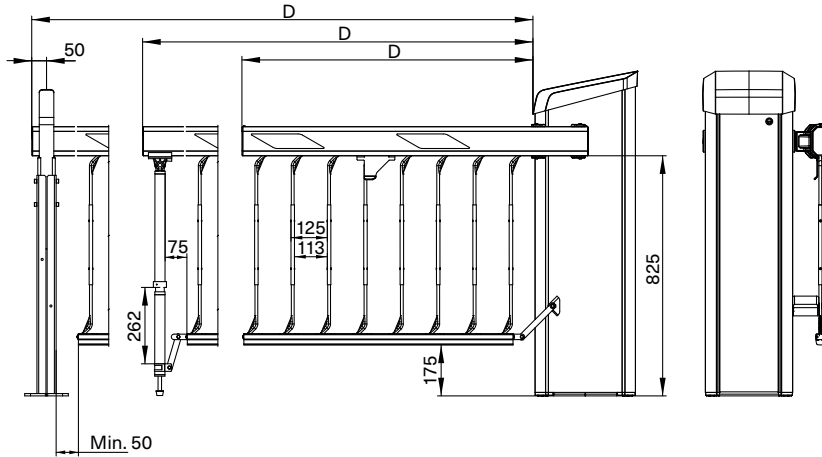

Access Pro-H with boom skirt with 1.30 m climb-over prevention

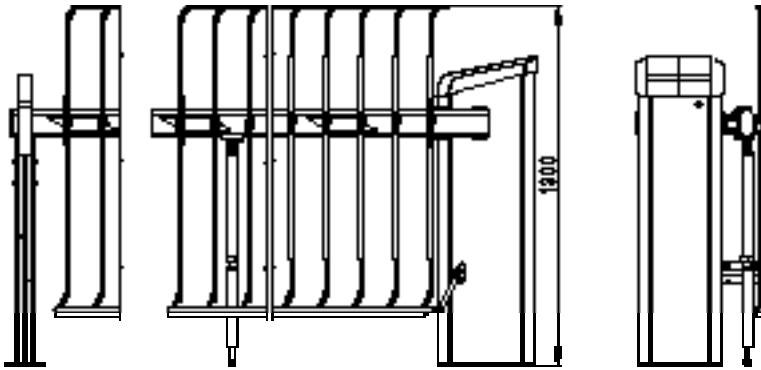

Access Pro-H with boom skirt with 1.80 m climb-over prevention

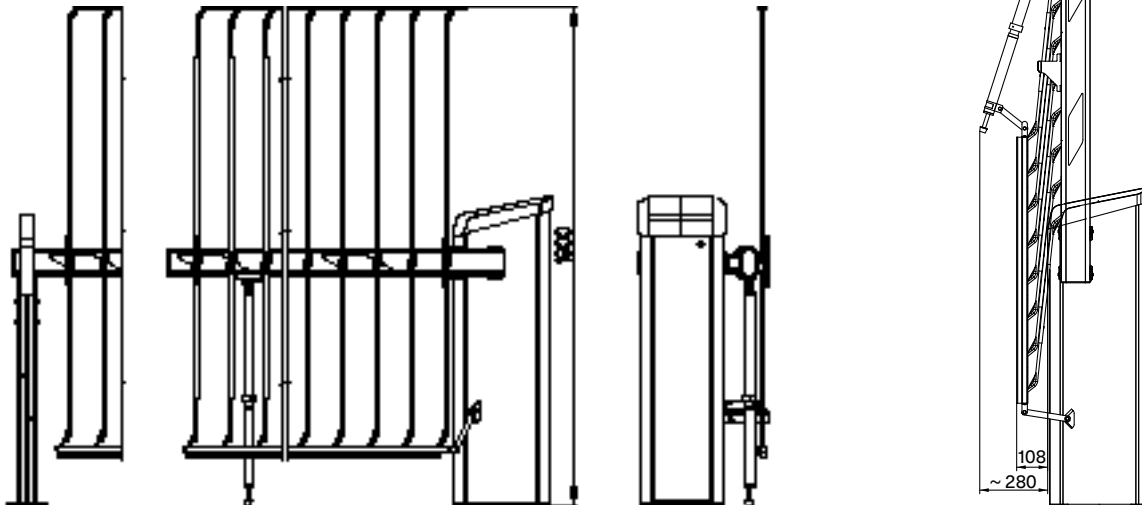

Complete dimensional drawings are available on request.

Standard boom skirt

Access to Progress

Magnetic stands for pioneering products – in every way. Our access control systems for vehicles or pedestrians clear the way for thousands of people every day – at car parks, toll gates, stations, airports and in buildings. Our technology is also pioneering, however: with innovative drives, intelligent control systems and well thought-out details it provides maximum safety and longevity. Are you also on the path to Magnetic?



Vehicle barriers

Access barriers
Parking barriers
Toll barriers
Special barriers



Pedestrian gates

Turnstiles
Swing gates
Tripod gates
Retractable gates
Wing gates



Terminals

Cars
Trucks

Germany
MAGNETIC AUTOCONTROL GMBH
Grienmatt 20
79650 Schopfheim
Phone +49 7622 695-5
Fax +49 7622 695-800
E-mail info@magnetic-germany.com

Australia
MAGNETIC AUTOMATION PTY LTD
38 Metrolink Circuit
Campbellfield, VIC 3061
Phone +61 3 9339 2900
E-mail info@magnetic-oz.com

Austria
FAAC GMBH
Münchner Bundesstraße 123
5020 Salzburg
Phone +43 662 853395-0
E-mail at.info@faacgroup.com

Benelux countries
FAAC BENELUX NV/SA
Industriezone 3B
8490 Jabbeke
Belgium
Phone +32 50 320202
E-mail info@magnetic-benelux.com

Brazil
MAGNETIC AUTOCONTROL LTDA
Av. Salim Antônio Curiati, 136
04690-050 – São Paulo
Phone +55 11 5660 8500
E-mail info@magnetic-br.com

China
MAGNETIC CONTROL SYSTEMS CO., LTD
No. 3 Building, No. 51
Lane 1159, Kang Qiao (East) Road
Kang Qiao Industrial Zone, Shanghai
Phone +86 21 68182970
E-mail info@magnetic-cn.com

France
FAAC FRANCE
377 Rue Ferdinand Perrier
69808 St Priest Cedex
Phone +33 4 72 21 86 89
E-mail info@magnetic-fr.com

India
MAGNETIC FAAC INDIA PVT LTD.
PRS Centre
Plot No. 373 to 376, 2nd Floor (West Wing)
1st Cross Street, Nehru Nagar
Old Mahabalipuram Road
Kottivakkam (Opp Rayala Technopark, Perungudi)
Chennai 600041
Phone +91 44 421 23297
E-mail info@magnetic-india.com

Middle East
FAAC MIDDLE EAST FZE
Dubai Silicon Oasis
PO Box 54886
Dubai
United Arab Emirates
Phone +971 4 3724193
E-mail info@magnetic-uae.com

N. and S. America (excl. Brazil)
FAAC INTERNATIONAL, INC
3160 Murell Road
Rockledge, FL 32955
USA
Phone +1 321 635 8585
E-mail info@magnetic-usa.com

Scandinavia
FAAC NORDIC AB
Box 125
284 22 Perstorp
Sweden
Phone +46 435 77 95 03
E-mail info@magnetic-nordic.com

Southeast Asia
MAGNETIC CONTROL SYSTEMS SDN. BHD
No. 17, Jalan Anggerik Mokara 31/54
Taman Perindustrian Kota Kemuning
40460 Shah Alam
Selangor Darul Ehsan
Malaysia
Phone +60 3 5123 0033
E-mail info@magnetic-malaysia.com