



## For economical access control

These access barriers from Magnetic are cost-optimised solutions for access control at car parks, company grounds, residential buildings and similar sites.

When the stipulated safety equipment is installed, these barriers – with their low impact forces – are approved for use wherever the movement of persons cannot be ruled out for structural reasons.\*

At the heart of the Access series is the innovative MHTM™ drive that is distinguished by its energy efficiency, lack of maintenance

and long service life – the Access series is designed for 10 million opening and closing cycles. Two basic variants are available, depending on requirements: the basis models Access and Access-L are characterised by a high level of underlying functionality. The two Pro models also offer expansion potentials with plug-in modules and exclusive accessories. By the way, Magnetic quality lies not just in the detail, but is also easily recognisable to all thanks to stylish design. The Access series has already been awarded two design prizes.

\* The Pro variant only with slow setting of the closing speed (2.5 s).



### Low operating costs

Thanks to their high energy efficiency, extremely long service lives, and simple maintenance, barriers from Magnetic are particularly cost-effective – an investment that will certainly pay off!



### Innovative drive technology

The MHTM™ drive unit is maintenance-free, energy-efficient and quiet. The high torque guarantees best possible operation even under extreme weather conditions.



### Legal security

All Magnetic barriers have a Declaration of Conformity in compliance with the Machinery Directive and a Declaration of Performance in line with the Construction Products Directive. Thus operators and those responsible for commissioning are always on the safe side in questions of liability.

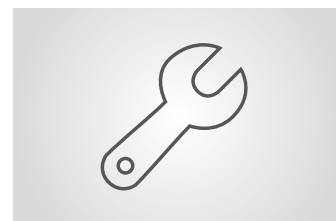

### Easy access to components

Two simple steps: control systems and the drive unit are easily reached by removing the cover and front plate. This increases user-friendliness and accelerates commissioning and service.

# Access

## Access barrier

- > High level of functionality for numerous applications
- > Very low operating costs thanks to efficient and long-lived MHTM™ drive
- > Ease-of-use and optimum accessibility thanks to well thought-out design
- > Legal security with Declarations of Conformity and Performance
- > Acclaimed design: German Design Award 2014 and Red Dot Design Award 2012
- > Designed for 10 million opening and closing actions



Technical data	Access	Access-L	Access Pro	Access Pro-L
Lane width	Max. 3.5 m	Max. 5.0 m	Max. 3.5 m	Max. 6.0 m
Opening/closing time	2.2 s	4.0 s	1.3 s	4.0 s
Power consumption	Max. 25 W	Max. 30 W	Max. 95 W	Max. 25 W
Drive technology	MHTM™	MHTM™	MHTM™	MHTM™
Voltage	85–264 VAC, 50/60 Hz	85–264 VAC, 50/60 Hz	85–264 VAC, 50/60 Hz	85–264 VAC, 50/60 Hz
Duty cycle	100 %	100 %	100 %	100 %
Housing dimensions (W x D x H)	315 x 360 x 915 mm	315 x 360 x 915 mm	315 x 360 x 915 mm	315 x 360 x 915 mm
Enclosure rating	IP 54	IP 54	IP 54	IP 54
Temperature range	–30 to +55 °C	–30 to +55 °C	–30 to +55 °C	–30 to +55 °C
Weight	40 kg	40 kg	40 kg	40 kg

Features	Access	Access-L	Access Pro	Access Pro-L
Standard colours	RAL 2000	RAL 2000	RAL 2000, 9006, 9007	RAL 2000, 9006, 9007
VarioBoom barrier boom	Standard	Standard	Standard	Standard
Control system	MGC	MGC	MGC Pro	MGC Pro
Integrated 2-channel detector for induction loops	Standard	Standard	Standard	Standard
Modular expansion of control system	Radio receiver and other detector modules	Radio receiver and other detector modules	Freely expandable	Freely expandable
Variable I/O assignment	–	–	Standard	Standard
No. of digital inputs	8	8	8	8
No. of relays/digital outputs	6/4	6/4	6/4	6/4
Input with test for safety light barrier/ Laser scanner	1	1	1	1
Selectable closing speed	Standard	Standard	Standard	Standard
Selectable opening speed	–	–	Standard	Standard

Options	Access	Access-L	Access Pro	Access Pro-L
Special colours	✓	✓	✓	✓
Boom extension set	✓	✓	✓	✓
Articulated boom*	✓	✓	✓	✓
Pendulum support**		✓		✓
Support post*	✓	✓	✓	✓
Boom drop contact	✓	✓	✓	✓
Boom interlock	✓	✓	✓	✓
Boom illumination, red	✓	✓	✓	✓
Light strips, red/green	✓	✓	✓	✓
Hood light	✓	✓	✓	✓
Key-operated switch	✓	✓	✓	✓
Radio module	✓	✓	✓	✓
Ethernet module			✓	✓
RS485 module			✓	✓
CAN module (counting)			✓	✓
Second detector module	✓	✓	✓	✓
GSM module	✓	✓	✓	✓
Safety light barrier/Laser scanner	✓	✓	✓	✓
Battery backup	✓	✓	✓	✓

\* max. 4.5 m lane width, max 3.5 m height

\*\* Pendulum support or a support post are required from a boom length of 3.5 m.

### Standard colours

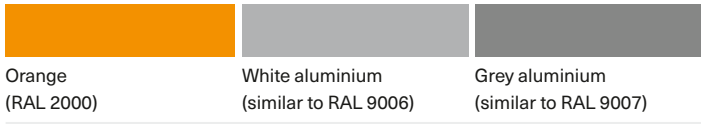

### Dimensional drawings

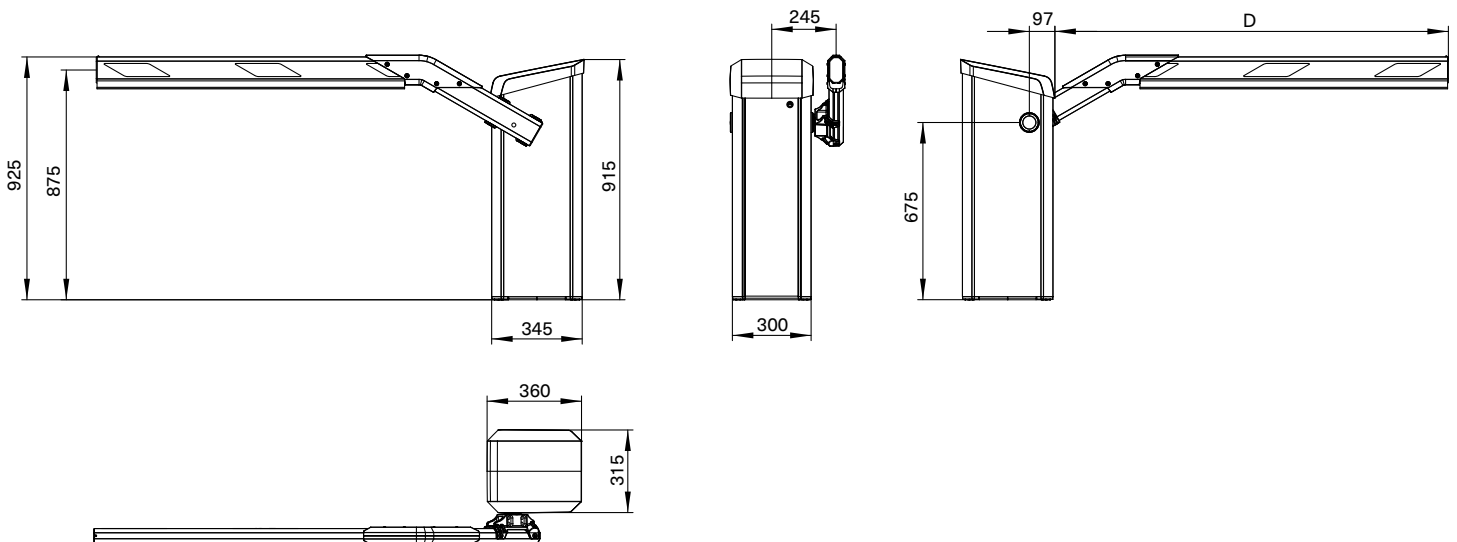

# Access to Progress

Magnetic stands for pioneering products – in every way. Our access control systems for vehicles or pedestrians clear the way for thousands of people every day – at car parks, toll gates, stations, airports and in buildings. Our technology is also pioneering, however: with innovative drives, intelligent control systems and well thought-out details it provides maximum safety and longevity. Are you also on the path to Magnetic?



## Vehicle barriers

- Access barriers
- Parking barriers
- Toll barriers
- Special barriers



## Pedestrian gates

- Turnstiles
- Swing gates
- Tripod gates
- Retractable gates
- Wing gates



## Terminals

- Cars
- Trucks

*Germany*  
**MAGNETIC AUTOCONTROL GMBH**  
 Grienmatt 20  
 79650 Schopfheim  
 Phone +49 7622 695-5  
 Fax +49 7622 695-800  
 E-mail [info@magnetic-germany.com](mailto:info@magnetic-germany.com)

*Australia*  
**MAGNETIC AUTOMATION PTY LTD**  
 38 Metrolink Circuit  
 Campbellfield, VIC 3061  
 Phone +61 3 9339 2900  
 E-mail [info@magnetic-oz.com](mailto:info@magnetic-oz.com)

*Austria*  
**FAAC GMBH**  
 Münchner Bundesstraße 123  
 5020 Salzburg  
 Phone +43 662 853395-0  
 E-mail [at.info@faacgroup.com](mailto:at.info@faacgroup.com)

*Benelux countries*  
**FAAC BENELUX NV/SA**  
 Industriezone 3B  
 8490 Jabbeke  
 Belgium  
 Phone +32 50 320202  
 E-mail [info@magnetic-benelux.com](mailto:info@magnetic-benelux.com)

*Brazil*  
**MAGNETIC AUTOCONTROL LTDA**  
 Av. Salim Antônio Curciati, 136  
 04690-050 – São Paulo  
 Phone +55 11 5660 8500  
 E-mail [info@magnetic-br.com](mailto:info@magnetic-br.com)

*China*  
**MAGNETIC CONTROL SYSTEMS CO., LTD**  
 No. 3 Building, No. 51  
 Lane 1159, Kang Qiao (East) Road  
 Kang Qiao Industrial Zone, Shanghai  
 Phone +86 21 68182970  
 E-mail [info@magnetic-cn.com](mailto:info@magnetic-cn.com)

*France*  
**FAAC FRANCE**  
 377 Rue Ferdinand Perrier  
 69808 St Priest Cedex  
 Phone +33 4 72 21 86 89  
 E-mail [info@magnetic-fr.com](mailto:info@magnetic-fr.com)

*India*  
**MAGNETIC FAAC INDIA PVT LTD.**  
 PRS Centre  
 Plot No. 373 to 376, 2nd Floor (West Wing)  
 1st Cross Street, Nehru Nagar  
 Old Mahabalipuram Road  
 Kottivakkam (Opp Rayala Technopark, Perungudi)  
 Chennai 600041  
 Phone +91 44 421 23297  
 E-mail [info@magnetic-india.com](mailto:info@magnetic-india.com)

*Middle East*  
**FAAC MIDDLE EAST FZE**  
 Dubai Silicon Oasis  
 PO Box 54886  
 Dubai  
 United Arab Emirates  
 Phone +971 4 3724193  
 E-mail [info@magnetic-uae.com](mailto:info@magnetic-uae.com)

*N. and S. America (excl. Brazil)*  
**FAAC INTERNATIONAL, INC**  
 3160 Murell Road  
 Rockledge, FL 32955  
 USA  
 Phone +1 321 635 8585  
 E-mail [info@magnetic-usa.com](mailto:info@magnetic-usa.com)

*Scandinavia*  
**FAAC NORDIC AB**  
 Box 125  
 284 22 Perstorp  
 Sweden  
 Phone +46 435 77 95 03  
 E-mail [info@magnetic-nordic.com](mailto:info@magnetic-nordic.com)

*Southeast Asia*  
**MAGNETIC CONTROL SYSTEMS SDN. BHD**  
 No. 17, Jalan Anggerik Mokara 31/54  
 Taman Perindustrian Kota Kemuning  
 40460 Shah Alam  
 Selangor Darul Ehsan  
 Malaysia  
 Phone +60 3 5123 0033  
 E-mail [info@magnetic-malaysia.com](mailto:info@magnetic-malaysia.com)

5806\_0046\_EN\_02